

Serial to Ethernet **User Manual**

USR-TCP232-302/304/306



V2.0

Be Honest & Do Best

Your Trustworthy Smart Industrial IoT Partner

Content

1. Introduction	- 4 -
1.1. Overview.....	- 4 -
1.2. Features.....	- 4 -
2. Get Started	- 5 -
2.1. Hardware interface introduction.....	- 5 -
2.1.1. Power supply	- 5 -
2.1.2. Serial port.....	- 6 -
2.1.3. Ethernet port.....	- 6 -
2.1.4. LED indicators	- 7 -
2.1.5. Reload button	- 7 -
2.1.6. Factory default setting	- 8 -
2.2. Quick test.....	- 8 -
2.2.1. Download software.....	- 8 -
2.2.2. Hardware connection.....	- 10 -
2.2.3. Parameter configuration	- 10 -
2.2.4. Data transmission test.....	- 13 -
2.2.5. Technical support and assistance	- 14 -
3. Configuration and parameter details	- 14 -
3.1. Web interface.....	- 14 -
3.1.1. Status	- 15 -
3.1.2. IP settings	- 17 -
3.1.3. Serial port settings	- 18 -
3.1.4. Expand function settings	- 20 -
3.1.5. Miscellaneous settings	- 22 -
3.2. Configuration software.....	- 23 -
3.2.1. Search device	- 23 -
3.2.2. Parameter settings.....	- 24 -
3.2.3. Open web server.....	- 24 -
3.2.4. Firmware upgrade	- 25 -
3.2.5. Restart the device	- 26 -
3.2.6. Restore to factory default settings	- 26 -

4. Operation mode - 27 -

 4.1. TCP server - 27 -

 4.2. TCP client - 28 -

 4.3. UDP server - 30 -

 4.4. UDP client - 32 -

 4.4.1. Transparent data transmission - 32 -

 4.4.2. Broadcast - 33 -

 4.4.3. Multicast - 34 -

 4.5. HTTP client - 35 -

5. Modbus Gateway - 36 -

 5.1. Modbus RTU to Modbus TCP..... - 36 -

 5.1.1. Ethernet master with serial slave - 37 -

 5.1.2. Serial master with Ethernet slave..... - 38 -

 5.2. Multi-host Modbus polling..... - 40 -

6. Additional features..... - 41 -

 6.1. Built-in webpage - 41 -

 6.1.1. Edit webpage file..... - 41 -

 6.1.2. Upgrade the webpage file - 41 -

 6.2. Index function - 42 -

7. Warranty..... - 43 -

8. Contact Us..... - 43 -

9. Disclaimer..... - 44 -

1. Introduction

1.1. Overview

USR-TCP232-302, USR-TCP232-304 and USR-TCP232-306 are cost-effective serial to Ethernet converter. They adopt Cortex-M0 solution, which has a main frequency up to 48MHz, providing fast transmission speed. Equipped with RS232/RS485/RS422 serial port and 10/100M Ethernet port, those products can connect to variety of serial devices to achieve transparent transmission via simple configuration to save manpower and shorten the development cycle. These products are widely used in smart traffic, unattended Weighing, manufacturing industry etc.

USR-TCP232-302, 304 and 306 are identical in software features, they both support transparent data transmission, Modbus gateway, user-defined webpage, heartbeat packet, registration packet, index function etc.

In hardware, TCP232-302 is RS232 to Ethernet converter, TCP232-304 is RS485 to Ethernet, TCP232-306 supports RS485/RS232/RS422, but RS485/RS232/RS422 can't work at the same time.

Table 1. Ordering Guide

Model	Description
USR-TCP232-302	1 x RS232, DB9 female, DC 5.5*2.1 power supply: 5~7 V
USR-TCP232-304	1 x RS485, 3P connector, DC 5.5*2.1 power supply: 5~7 V
USR-TCP232-306	1 x RS232/485/422, 4P connector + DB9 male, DC 5.5*2.1 & block terminal power supply: 5 ~ 36V

1.2. Features

- ARM core, Cortex-M0 solution, equipped with deeply optimized TCP/IP protocol stack. It has low latency and strong scalability, stable and reliable.
- Supports custom webpage function to help users improve brand influence.
- 1.5KV built-in network Magnetic Isolation.
- Wide baud rate: 600~460.8 Kbps, multiple parity bit: NONE, Odd, Even, Space, Mark
- Supports Modbus RTU to Modbus TCP protocol conversion and multi-host polling.
- Supports keepalive mechanism to quickly detect the dead connections and reconnect.
- Supports hardware and software watchdog, automatically restarts when the device goes down.
- 10/100Mbps Ethernet port and support Auto MDI/MDIX.
- Supports a wide industrial operating temperature, -25°C~75°C.
- Versatile operation modes: TCP Server, TCP Client, UDP, HTTP client.
- Support virtual COM, COM Port Redirector USR-VCOM (windows).

- Easy to config: built-in webpage and AT command to set parameters.

2. Get Started

2.1. Hardware interface introduction

2.1.1. Power supply

The USR-TCP232-302 and USR-TCP232-304 provide DC jack power supply interface. Power supply range: 5~7V DC.

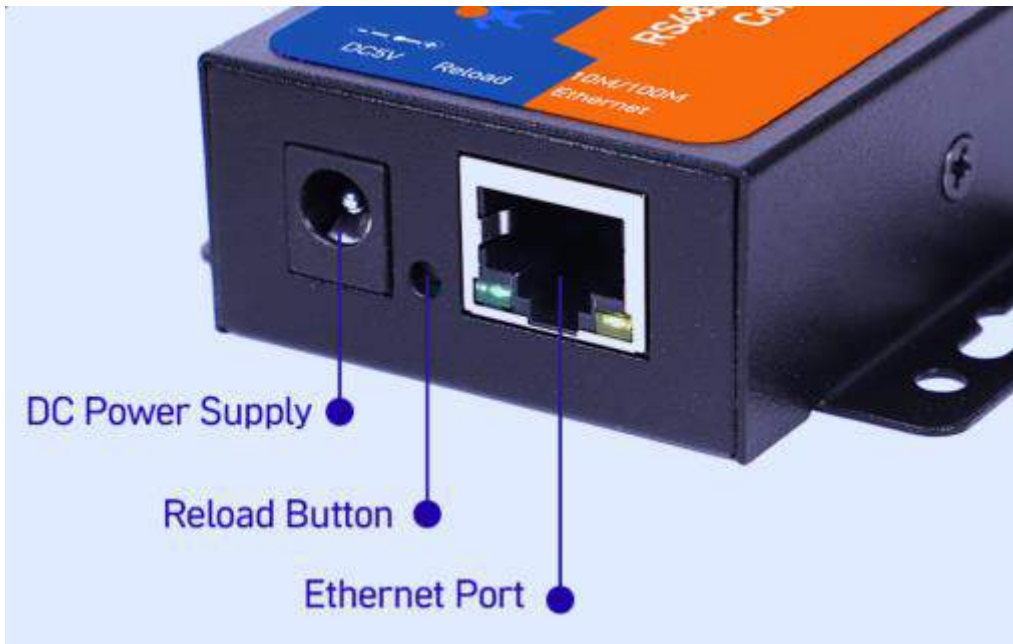

Figure 1. TCP232-302/304 DC power supply



The USR-TCP232-306 provides 2-pin power supply terminal blocks and DC jack. The power supply support anti-reverse protection. Power supply range: 5~36V DC.



Figure 2. TCP232-306 power supply

2.1.2. Serial port

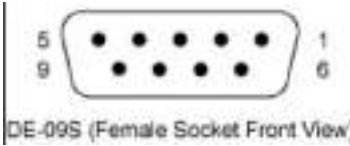
Table 2. Serial port pin description

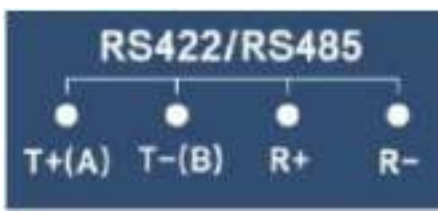
Model		Type	Description
USR-TCP232-302		RS232, DB9 female	2: RxD 3: TxD 5: GND
USR-TCP232-304		RS485	A: Data+ B: Data-
USR-TCP232-306		RS232, DB9 male	2: TxD 3: RxD 5: GND
		RS485/RS422	For RS485 A: Data+ B: Data- For RS422 T+: Transmit data (+) T-: Transmit data (-) R+: Receive data (+) R-: Receive data (-)

2.1.3. Ethernet port

USR-TCP232-30x series adopt 10Base-T/100Base-TX adaptive Ethernet RJ45 interface which supports automatic MDI/MDIX connection.

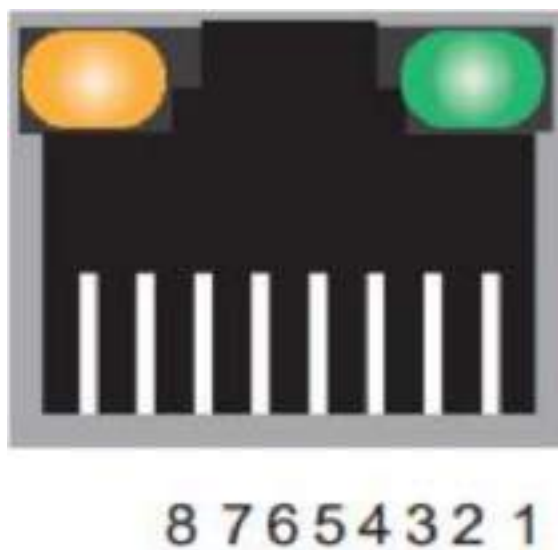

Figure 3. RJ45 with light

Table 3. Ethernet pin assignment

Pin number	Signal name
1	Send data+(TD+)
2	Send data-(TD-)
3	Receive data+(RD+)
6	Receive data-(RD-)
4, 5, 7, 8	Unused

2.1.4. LED indicators

In USR-TCP232-30x series, only USR-TCP232-306 has LED indicators. The LED indicators description is in the following table.

Table 4. LED indicators description

LED name	Status	Description
Power	ON	Power supply is normal
	OFF	No power supply or abnormal power supply
Work	Blinking	System is booted up and running
Link	ON	TCP connection is established, or the device works in UDP mode
TX	Blinking	Serial port is transmitting data
RX	Blinking	Serial port is receiving data

2.1.5. Reload button

After the USR-TCP232-30x is powered on, keep pressing the reload button for 3~15 seconds and then release to restore the 30x device to the factory default settings.



Figure 4. Reload button

2.1.6. Factory default setting

The USR-TCP232-30x serial device server comes with the following default setting.

Table 5. Default parameter

Parameter	Default Values
Username	admin
Password	admin
Device IP	192.168.0.7
Subnet Mask	255.255.255.0
Gateway IP	192.168.0.1
COM port	115200, N, 8, 1
COM operation mode	TCP client

2.2. Quick test

USR-TCP232-30x series serial server has a built-in Web server, which provides a convenient way to access and configure the serial server. Users can use Edge, Firefox or Google browser to access it. This chapter is a quick introduction to the USR-TCP232-30x series of serial server products. It is recommended that users read this chapter and follow the instructions once for the system, and you will have a basic understanding of the product. For specific function details and instructions, please refer to the subsequent chapters.

2.2.1. Download software

Download the software from PUSR's website:

Config software: 插入设置软件下载链接

Test software: <https://www.pusr.com/support/download/usr-tcp232-test-V13.html>

After downloading, run the config software. It is strongly recommended for the users to set the Network Parameters through configuration tool first. Other device-specific configurations can later be carried out via user-friendly Web-Interface.

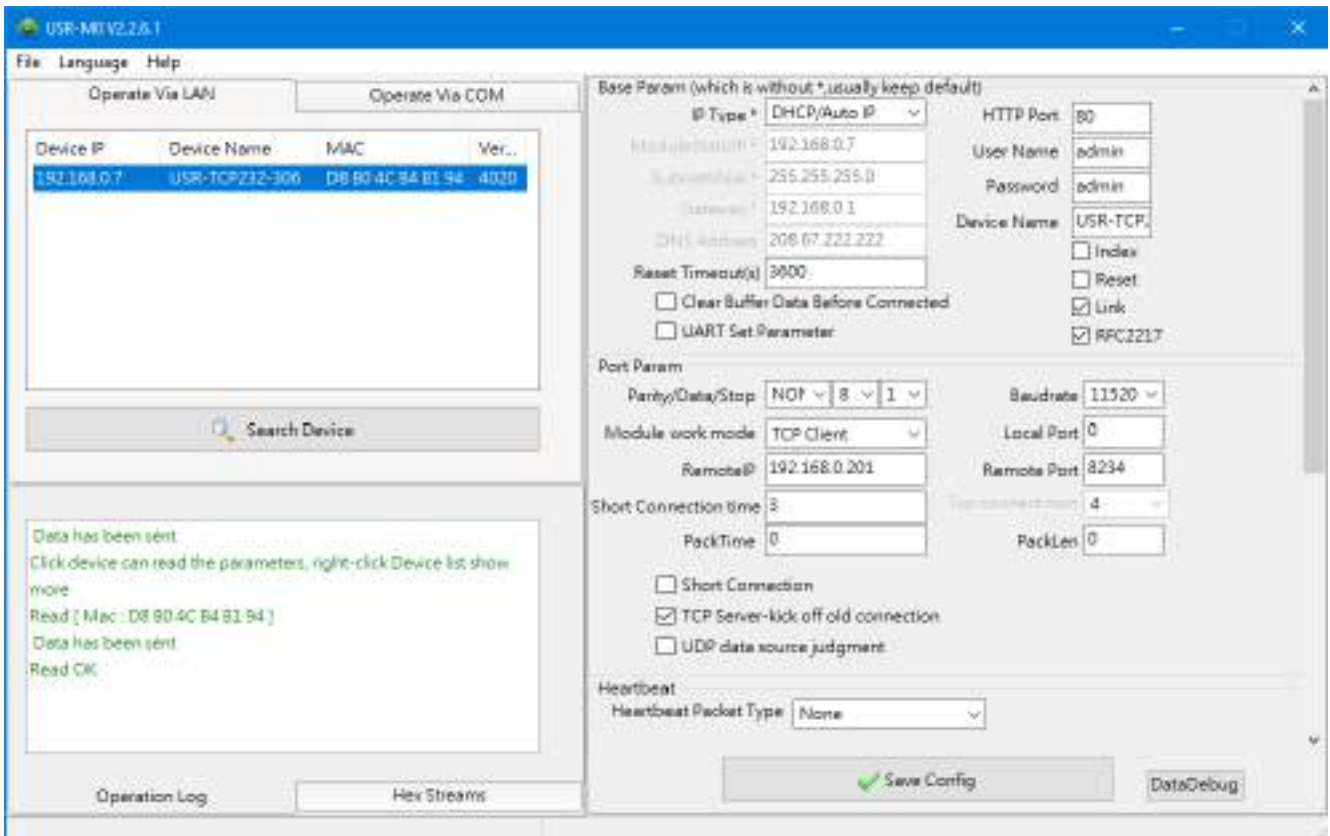

Figure 5. Config software

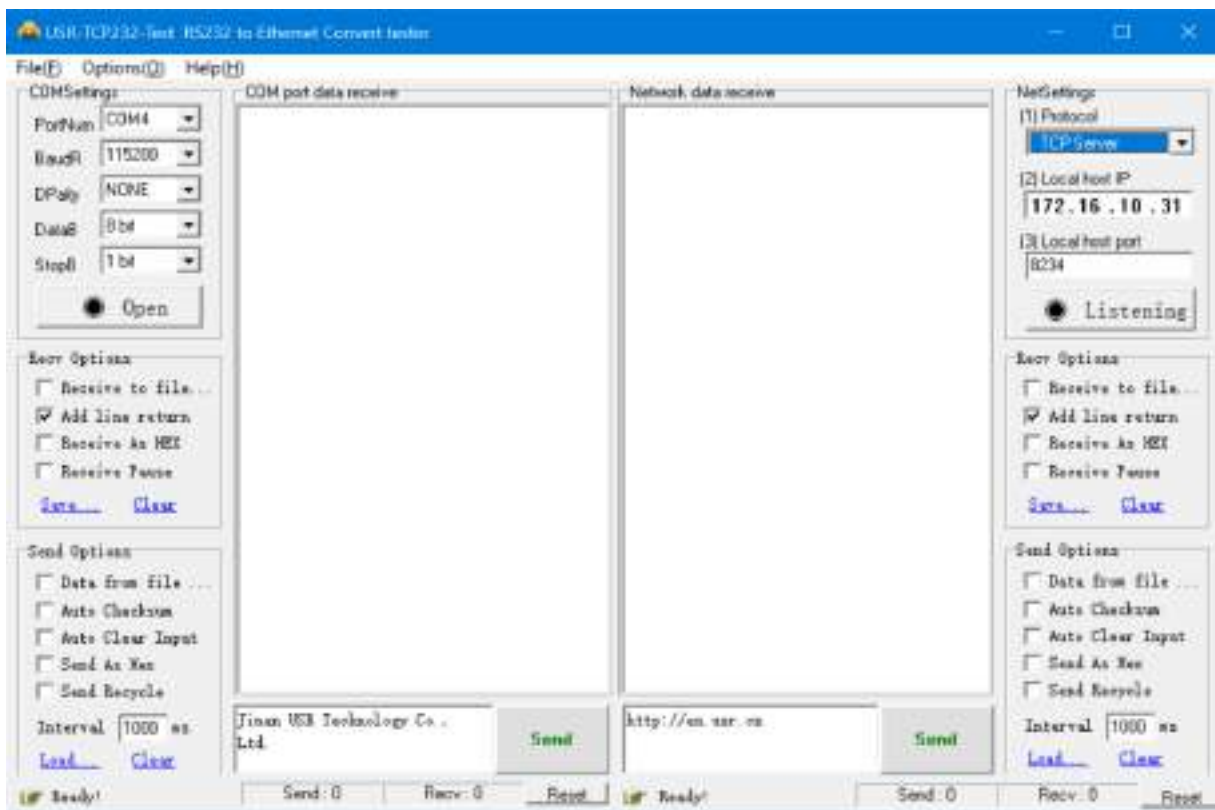

Figure 6. Test software

2.2.2. Hardware connection

For fast networking of USR-TCP232-30x series serial server, you need to prepare a PC, a router, a serial server, a network cable, a serial cable, and a DC5V/1A power supply. The hardware connection is shown in following figure. To establish a TCP / IP network all devices must be connected to the same network either locally or via gateway connections.



Figure 7. Hardware connection

2.2.3. Parameter configuration

Using the config software,

1. Users can search out the 30x device,
2. Set the IP type as DHCP/Auto IP,
3. Save config,
4. Search the device again,
5. Open the webpage, the user will be navigated to the login page, the username and password are both "admin" .

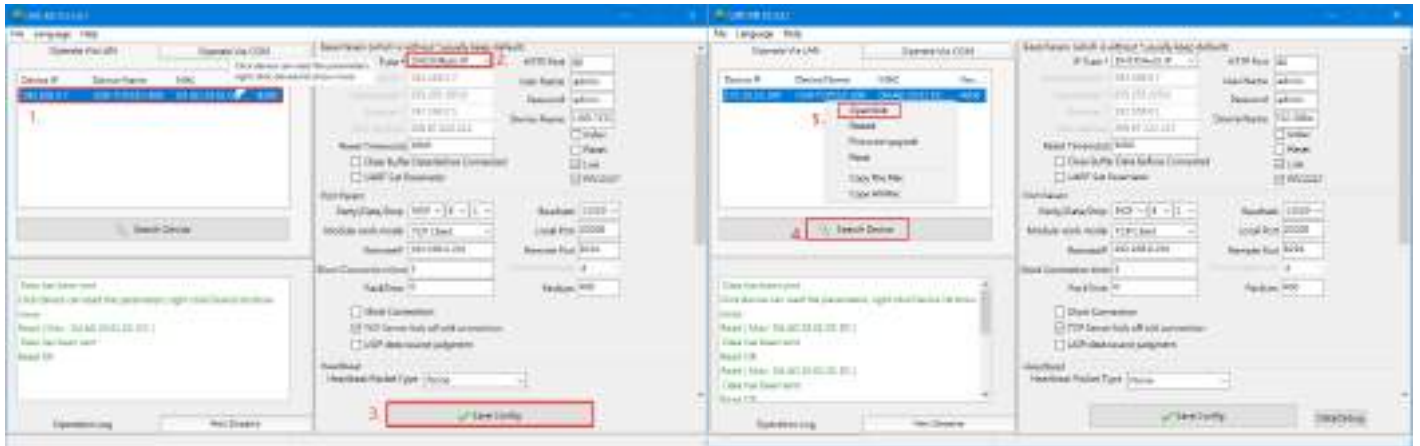

Figure 8. Search and basic settings

After entering the username and password, click "OK" and the server will authenticate. After success, you will enter the main page of the Web server, as shown in the following figure.



Figure 9. Current status

In serial port page, set the remote IP to 172.16.11.31, then save parameters and restart the module.



Figure 10. Serial port parameters

After restarting, check the parameters via the config software. From the picture, we can see the parameters has already taken effect.

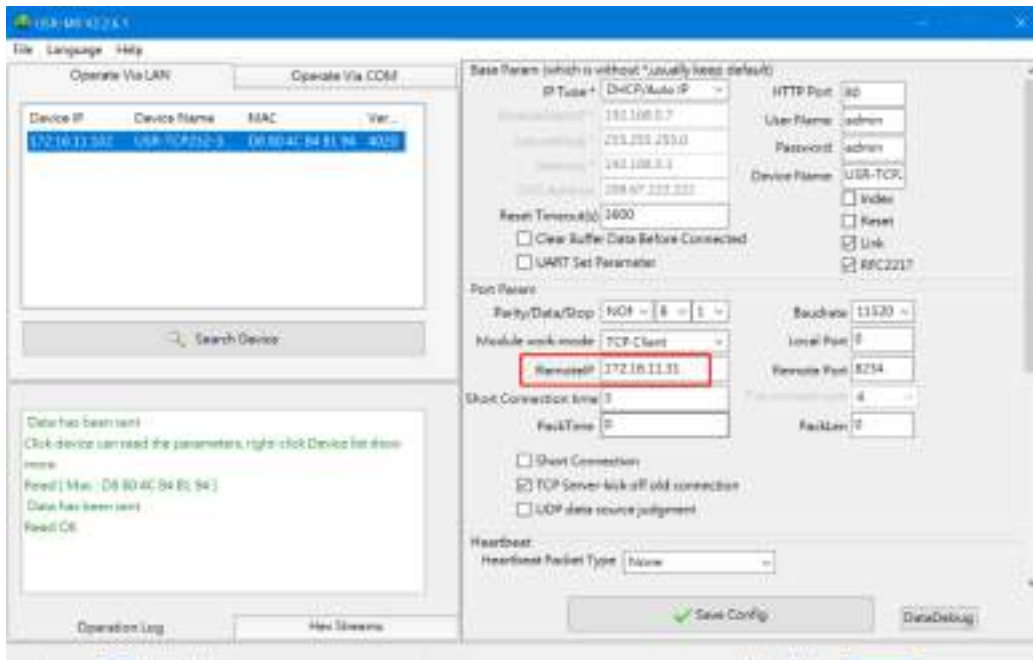

Figure 11. Parameters checking via config software

The IP address of the PC must be modified to ensure that it is in the same local area network as the IP of the serial server if you want to connect 30x to PC directly via a net cable. The default IP address of serial server is: 192.168.0.7. Set the PC's IP address as: 192.168.0.X (X is any valid value from 2 to 253 except 7). The specific

Windows system operation page is shown in the following figure. you can access the Web page of the USR-TCP232-30X series serial server through browser as mentioned above.



Figure 12. IP setting of PC

2.2.4. Data transmission test

Run the test software on the PC, set the protocol as TCP Server, local IP keep the same with the remote IP of 30x device, local host port keeps the same with the remote port of 30x device. After the TCP connection is established, users can check the link indicator, it will keep steady on.

In this test, we use the default serial port parameters (115200, N, 8, 1) to test. Users can also to modify the baud rate, data bit and other parameters of the serial port via webpage or config software as needed.

The following picture shows an example of parameters setting to test transparent transmission.

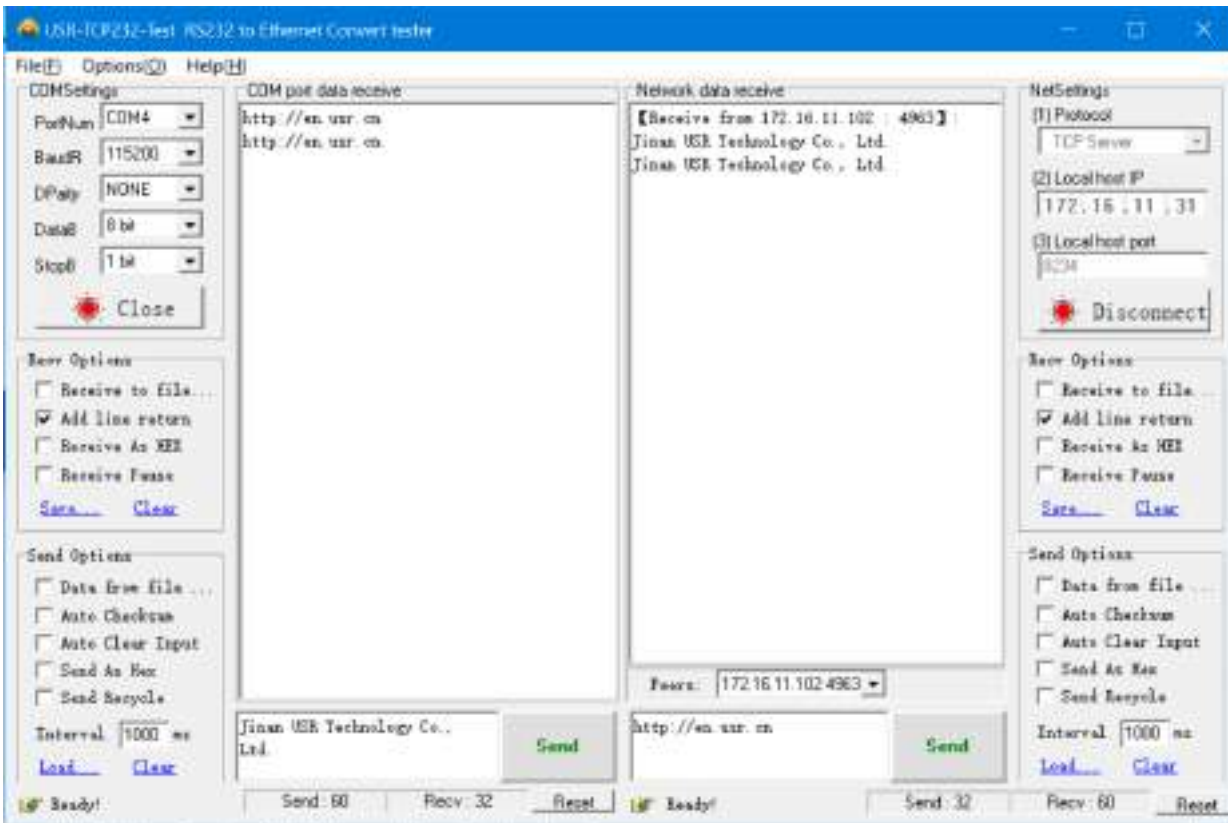

Figure 13. Data transmission test

2.2.5. Technical support and assistance

Please visit the USR IoT website: <https://www.pusr.com> where you can find the latest information about the product. Contact your distributor, sales representative, or PUSR's support center:

<http://h.usriot.com/index.php?c=frontTicket&m=sign> for technical support if you need additional assistance.

Please have the following information ready before you submit a ticket:

- Product model
- Description of your peripheral attachments
- Description of your software (firmware version, application, function description, etc.) - A complete description of the issue and steps to reproduce

3. Configuration and parameter details

3.1. Web interface

Every USR-TCP232-30X Industrial Serial Device Server is equipped with a built-in web server in the firmware. Therefore, the device can be accessed by using a web browser for configuring by entering the device's IP address in the URL field of your web browser. An authentication will be required and you will have to enter the username (Default value is "admin") and password (Default value is "admin") for accessing the web interface as shown

in Figure 14. This approach (web interface) for configuring your device is the most user-friendly. It is the most recommended and the most common method used for USR-TCP232-30X Serial Device Server Series. Please go to its corresponding section for a detailed explanation



Figure 14. Login page

3.1.1. Status

After entering the correct username and password and the authentication is successful, you will enter the main page of the Web, as shown in figure 15. The main page can be roughly divided into three areas. The upper area displays the logo, the lower left area is the function menu area, the middle area is the main function display area, and the lower right area is the help document area. Figure 15 illustrates the status page of the web interface.



Figure 15. Current status

The function of the device status part is to display some specific information of the current device, including module name, IP address, MAC address, etc.

Table 6. Description of Current status

Parameter Item	Description
Module name	The name of the serial server, which can be customized by the user on the "Miscellaneous settings" page.
IP address	The IP address of the serial server.
MAC address	The MAC address of the serial server.
Remote IP/TX/RX	IP: The IP of remote host, it displayed once the TCP connection is established, Tx: The data count from serial to network Rx: The data count from network to serial When the TCO232-30X work in TCP server mode, the page can display up to 5 connection information.

3.1.2. IP settings

You must assign a valid IP address to the USR-TCP232-30x before it will work in your network environment. The IP address must be unique within the network. If the device is connected to the Internet and should connect to other servers over the Internet to get some services such as Network Time Protocol (NTP) server, you will need to configure the DNS server to be able to resolve the host name of the NTP server. The detailed description of the configuration parameters on this interface is shown in Table 7.



Figure 16. IP settings

Table 7. Detail description of IP settings

Parameter Item	Description
IP type	DHCP: To obtain required TCP/IP configuration information from router. Static IP: User need to set the IP information manually.
IP address	IP address is a 32-bit address assigned to devices connected to the Internet. The IP address consists of two fields: the network number field (Net-id) and host number field (host-id). In order to facilitate the management of IP addresses, IP addresses are divided into five categories: Class A, B, and C addresses are unicast addresses, Class D addresses are multicast addresses, Class E addresses are reserved addresses for future special purposes. The IP addresses currently in large numbers belong to three types of addresses: A, B, and C.

Subnet mask	The mask is a 32-bit number corresponding to an IP address. Some of these numbers are 1, and the others are 0. The mask can divide the IP address into two parts: the subnet address and the host address. The part of the IP address corresponding to the 1 bit in the mask is the subnet address, and the other bits are the host address. The mask for class A addresses is 255.0.0.0, the mask for class B addresses is 255.255.0.0, the mask for class C addresses is 255.255.255.0.
Default gateway	The default gateway in the host is usually called the default route. The default route (Default route) is the route chosen by the router when no other route exists for the destination address in the IP packet. All packets whose destination is not in the router's routing table will use the default route.
DNS	The IP address of the DNS server. When users need to access information online through domain name, like www.pusr.com . DNS translates domain names to IP so browsers can load Internet resources.

3.1.3. Serial port settings

The main function of the serial device server is to carry out two-way transparent transmission of standard serial bus data (RS-232, RS-485, RS-422) and standard Ethernet data supporting TCP/IP protocol to solve common serial equipment Networking problems on the Internet. The Port configuration page can configure the parameters of the serial port and socket, as shown in following picture.



Figure 17. Settings of serial port

Details on work mode connectivity protocols and its settings of TCP232-30X series are given in **Chapter 4** Operation modes, this section will only focus on the part of parameter description. The description of the configuration parameters on this interface is shown in Table 8.

Table 8. Detail description of serial port

Parameter Item	Description
Baud rate	This sets the port's data transfer speed. Choices are from 600–230400. Set this to match the baud rate setting of the connected device. Default is 115200.
Data size	This sets the number of bits used to transmit one character of data. Choices are: 7 and 8. Set this to match the data bit setting of the connected device. Default is 8 (which is the default for the majority of serial devices).
Parity bits	This bit checks the integrity of the transmitted data. Choices are: None, Odd, Even. Set this to match the parity setting of the connected device. Default is None (which is the default for the majority of serial devices).
Stop bits	This indicates that a character has been transmitted. Set this to match the stop bit

	setting of the connected device. Choices are: 1 and 2. Default is 1 (which is the default for the majority of serial devices).
Local Port Number	When TCP232-30X work in TCP server mode, the local port is the listening port.
Remote Port Number	When TCP232-30X work in TCP client mode, the remote port is the target port to connect to.
Work mode	Please to check Chapter4 for more information.
Remote Server Addr	When TCP232-30X work in TCP client mode, the remote server address is the target address to connect to.
RESET	<p>This function is available in TCP client mode. The 30X device connect to TCP server actively when works as TCP client. The 30X device will restart if the TCP connection is not established after 30 attempts.</p> <p>The Reset function is mainly used to initialize the 30X device by restarting when the 30X program runs out or crashes and counter abnormal TCP connection. Then to restore the 30X to normal operation under certain conditions.</p>
LINK	The LINK indicator works only after the LINK function is enabled.
INDEX	See more information in chapter 6.1.1.
Similar RFC2217	Enabling this function allows users to use customized RFC2217 commands on the network to dynamically modify the serial port's baud rate, data bits, stop bits, and parity bits. This function is only allowed when the working mode is TCP Server and TCP Client. Note that this protocol is used to change the serial port parameters of TCP232-30X.
Tcp Quick Ack	

3.1.4. Expand function settings

USR-TCP232-30X series provide rich additional function which is displayed in this function tab page. The function detail information will be described in the following table, some more important function is introduced in relevant chapters.

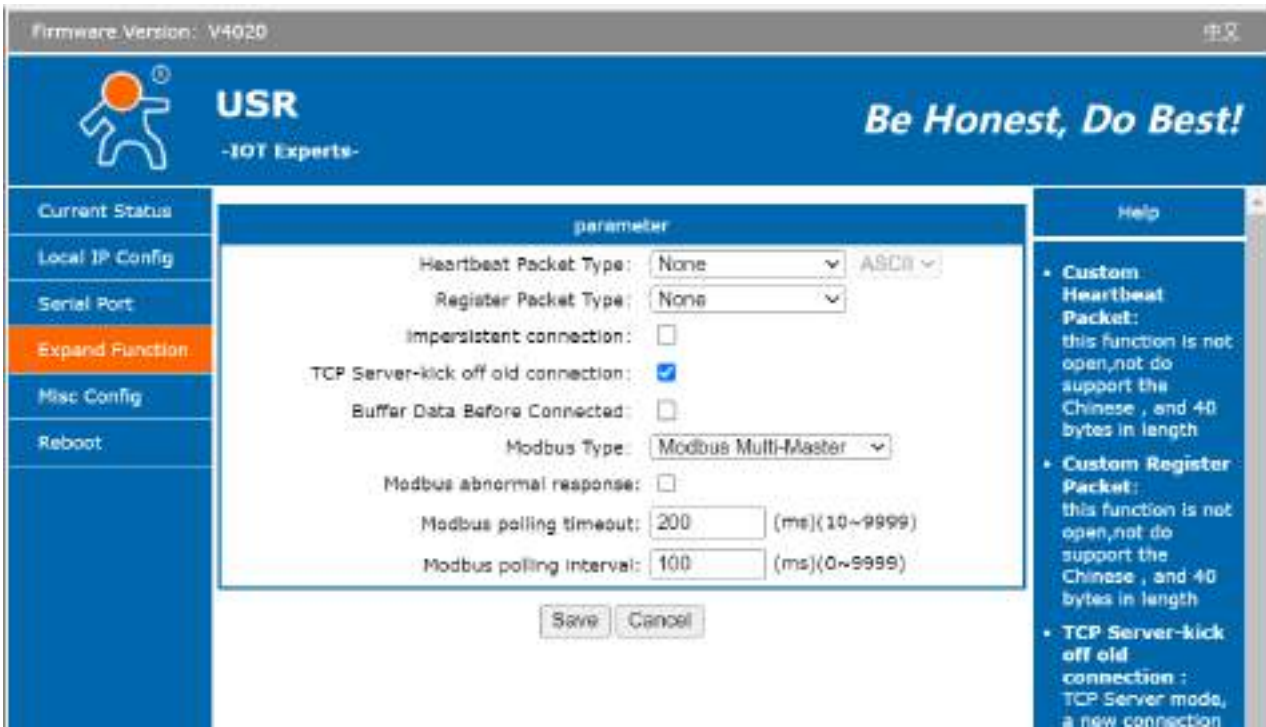

Figure 18. Settings of expand function

Table 9. Detail description of expand function

Parameter Item	Description
Heartbeat Packet	<p><i>UART Heartbeat:</i> TCP232-30X sends heartbeat packet to serial device at preset interval, the content of the packet can be either hex or string. Users can use UART heartbeat to query serial device to reduce communication pressure on server.</p> <p><i>Net heartbeat:</i> It's available in TCP client and UDP client mode. TCP232-30X sends a heartbeat packet data to inform the server that it is still online, when it fails to receive data from the serial device within the set time.</p>
Register Packet	<p>It's available in TCP client and UDP client mode. Users can identify different</p> <p>MAC: The content of the register packet is the MAC address of TCP232-30X,</p> <p>User-defined: User can define the content of the register packet by themselves,</p> <p>USR Cloud: This is used for registering to USR cloud.</p>
Registered Direction	<p>Connect with: TCP232-30X sends register packet only once when the network connection is established.</p> <p>Data with: TCP232-30X add register packet in front of each packet of data sent by the serial port device.</p> <p>Both of above:</p>
Impersistent connection	<p>This function is available in TCP client mode. If the serial port or network port receives</p>

	no data within the setting time, the connection will be automatically disconnected to save server resources. The default time is 3 seconds. Range: 2~255 s.
TCP Server-kick off old connection	When the connection exceeds the maximum number (default is 4), actively kick out the oldest connection (first in first kick out).
Buffer Data Before Connected	Click the option to enable serial buffer. By default, TCP232-30X will empty its serial buffer when a new TCP connection is established. This means that the TCP application will not receive buffered serial data during a TCP link breakage. To keep the serial data when there is no TCP connection and send out the buffered serial data immediately after a TCP connection is established, you can disable this option.
Modbus	See more information in Chapter 5

3.1.5. Miscellaneous settings

This configuration tab includes several system level settings, such as device name, system log, username, and password. Most of these settings are optional.

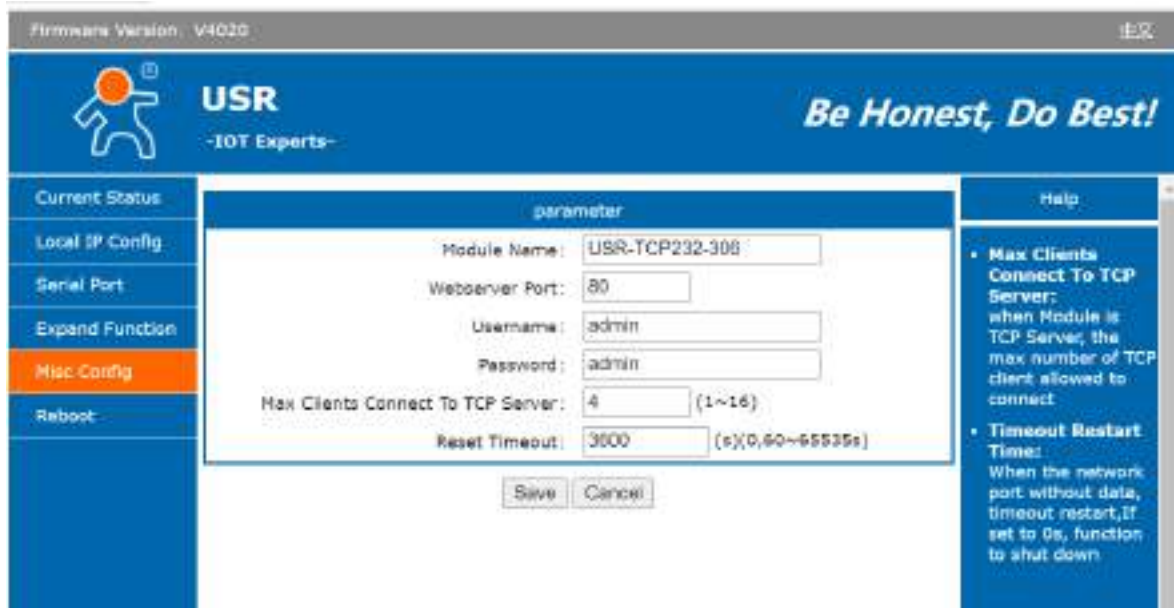

Figure 19. Settings of miscellaneous function

Table 10. Detail description of miscellaneous function

Parameter Item	Description
Module name	The name of the device, up to 5 characters, can't be null
Webserver port	Webserver listen port NO. The default is 80. Range 1-65535
Username	The username of web console and can be modified. up to 5 characters, can't be

	NULL
Password	The password of web console and can be modified. up to 5 characters, can be NULL
Max Clients	This option specifies the maximum number of remote devices/clients (with maximum of 16 clients), that can be connected to the serial device.
Reset timeout	This function is used for the serial device server without any data transmission or reception for a long time, and the serial server automatically restarts. If the restart time is set between 0 and 59 seconds, this function does not take effect. Only when the time is set to be greater than or equal to 60 seconds, the restart function of the device without data will take effect.

3.2. Configuration software

The parameters are also can be configured by config software. The parameter function is already introduced in Chapter 3.1. In this chapter, we how to config the parameters via config software.

3.2.1. Search device

Run the config software, if the USR-TCP232-30X Serial Device Server is already connected to the same gateway as your PC, the device can be accessed via broadcast packets. Users can search all the TCP232-30X Series device servers on the network and show them on the Serial Device Server List Area of the utility.

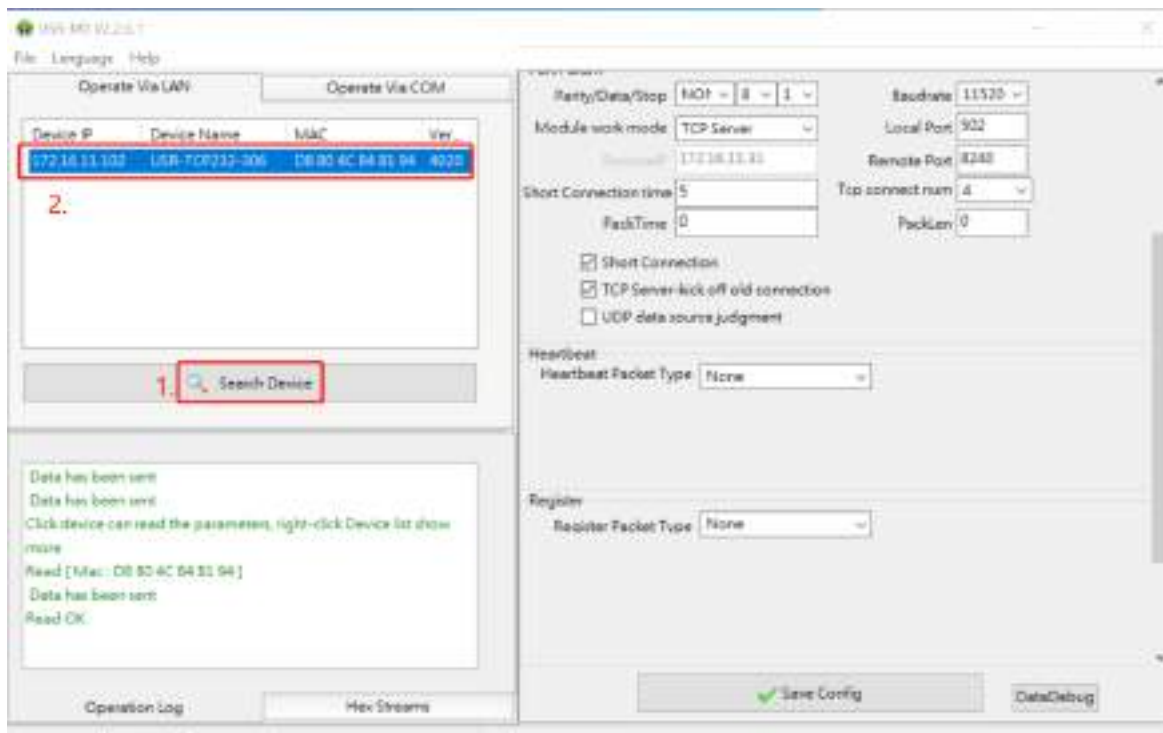

Figure 20. Search device

3.2.2. Parameter settings

Users can modify the parameters as needed, and the click “Save Config” to make the parameters take effect. More parameters can be checked by scrolling down or up.

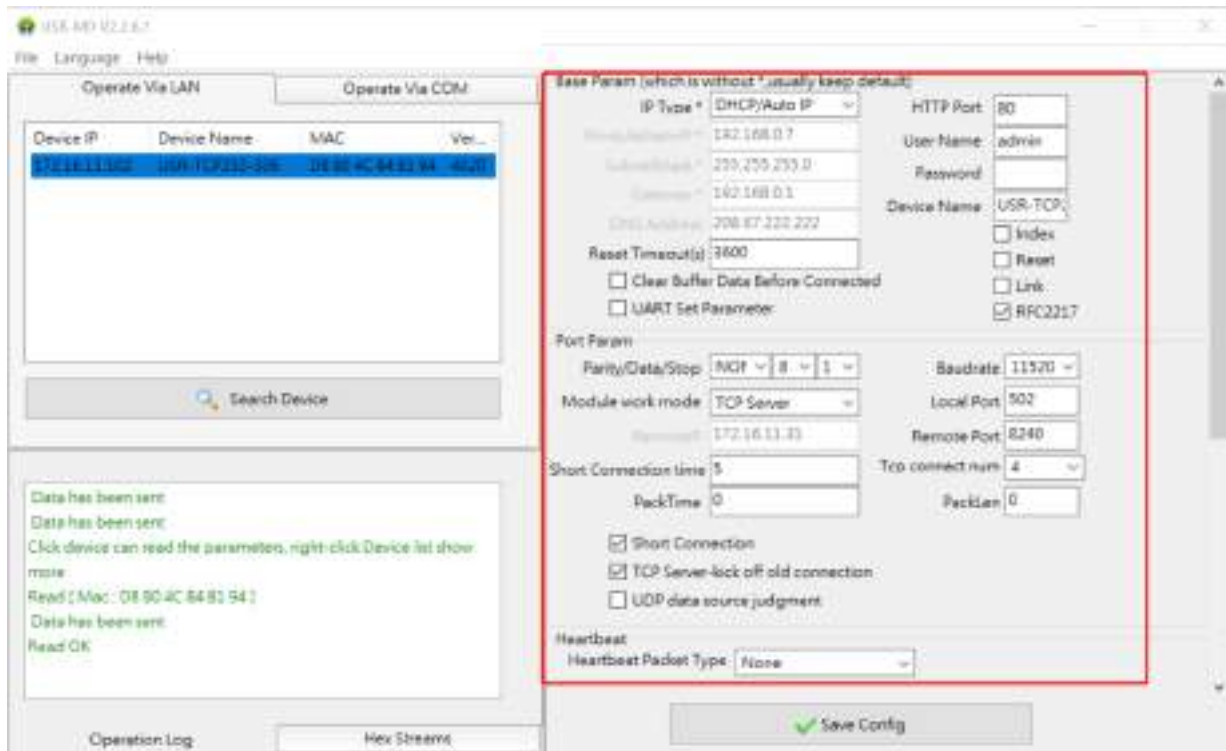

Figure 21. Parameters configuration via config software

3.2.3. Open web server

Users can visit the web server of serial device server conveniently with configuration tool. Select the device you want to visit and right click, then click External web config ,you will open the web server with default browser such as Google Chrome.

1. Right-click a desired device to display the settings menu,
2. Select OpenWeb

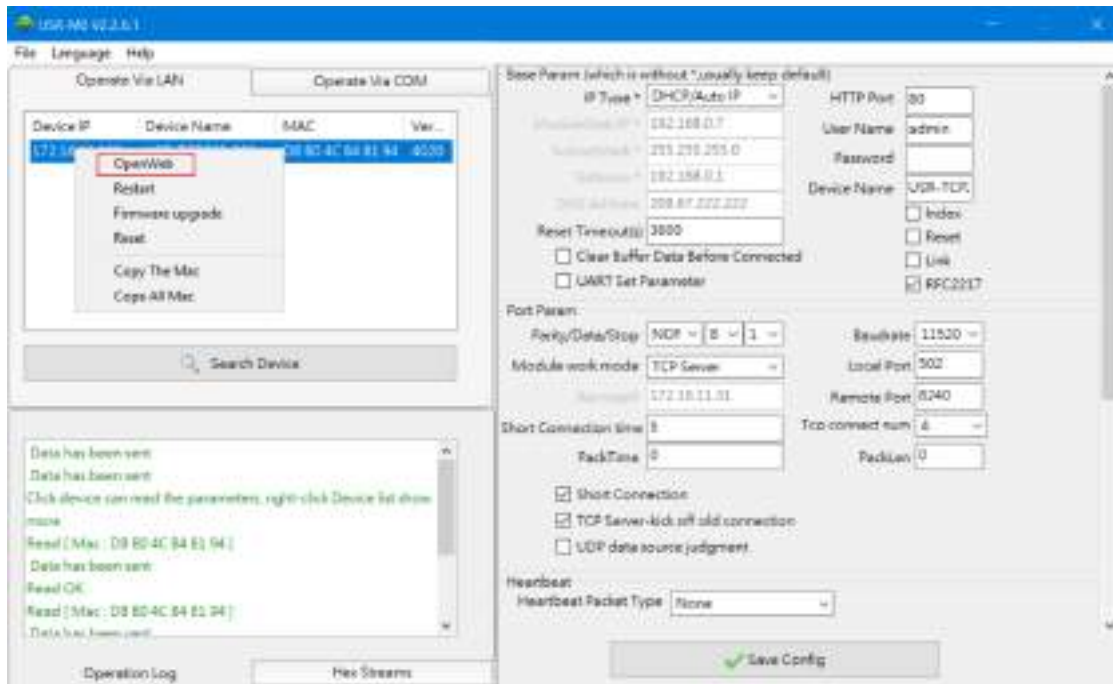

Figure 22. Open web server via config software

3.2.4. Firmware upgrade

USR IoT continually upgrades its firmware to add new features and optimize performance. Please contact the sales to obtain the latest version of the firmware. Users can upgrade the firmware by themselves. When upgrading firmware, the 30X device must be in the same LAN network with PC.

3. Right-click a desired device to display the settings menu,
4. Select Firmware upgrade

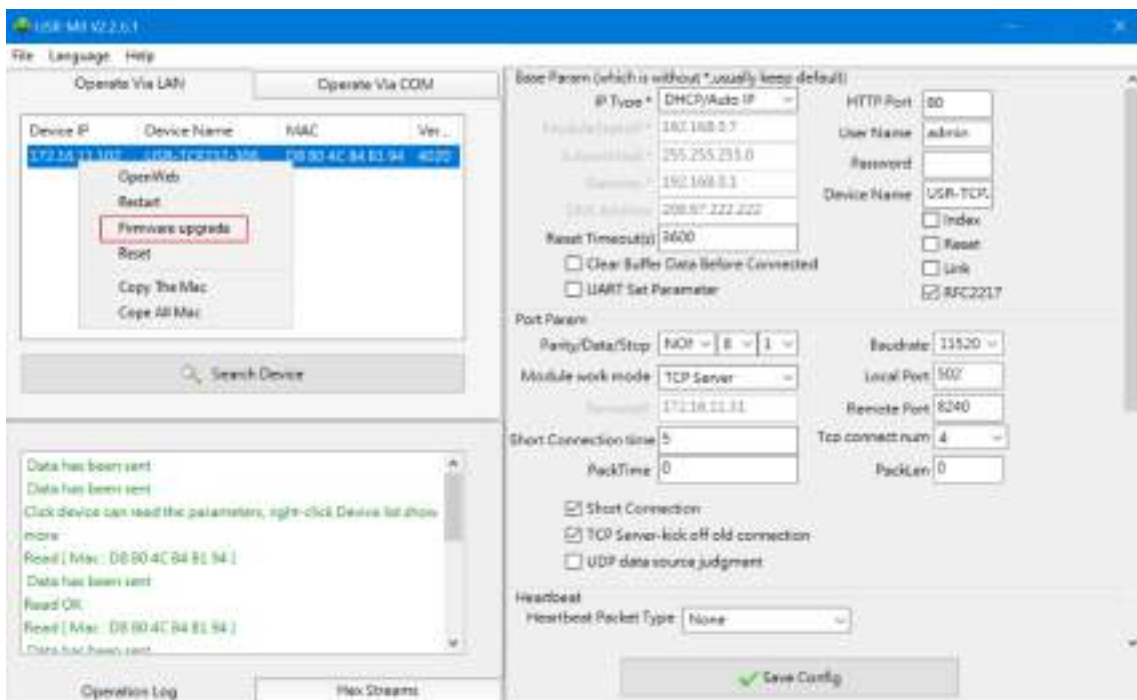

Figure 23. Firmware upgrade

3.2.5. Restart the device

This function is available to allow you to reset the serial device server. The function disconnects both the ethernet and serial connections. The function also allows the serial device server to save new configuration settings to flash memory. To reset the device:

5. Right-click a desired device to display the settings menu,
6. Select Restart

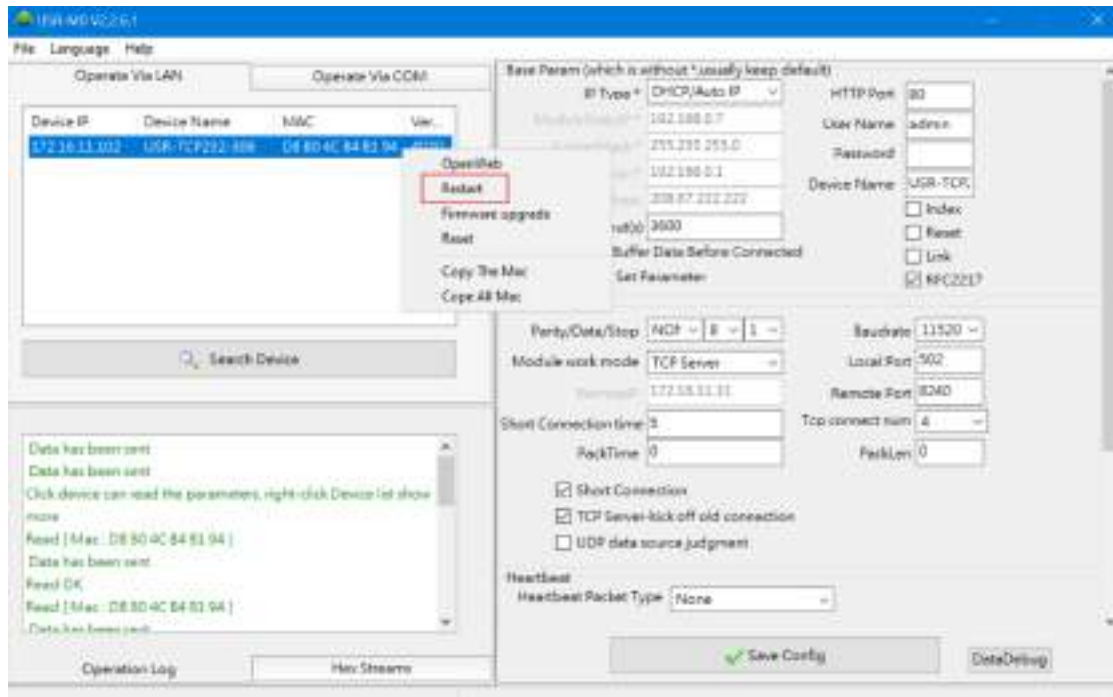

Figure 24. Restart the device

3.2.6. Restore to factory default settings

The configuration utility provides the function to restore the serial device server to factory default settings. If you really want to restore the serial device sever to factory default settings, please click reset button to continue.

1. Right-click a desired device to display the settings menu,
2. Select Reset

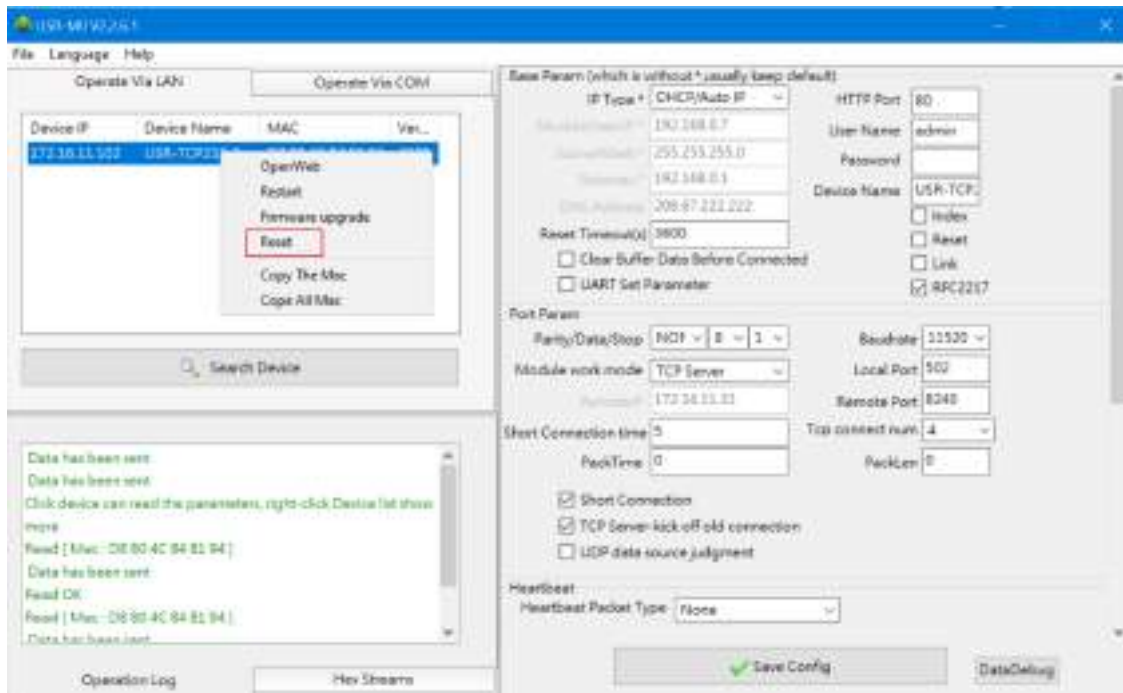

Figure 25. Restore to factory default settings

4. Operation mode

4.1. TCP server

In TCP server mode, the TCP connection is initiated from the host (TCP client) to the USR-N5X0 Series device server. This operation mode supports a maximum of 16 simultaneous connections. Once the connection is established between the 30x series and the remote host computer (remote TCP client), data can be transmitted in both directions. The work mode can be set in “serial port” tab.

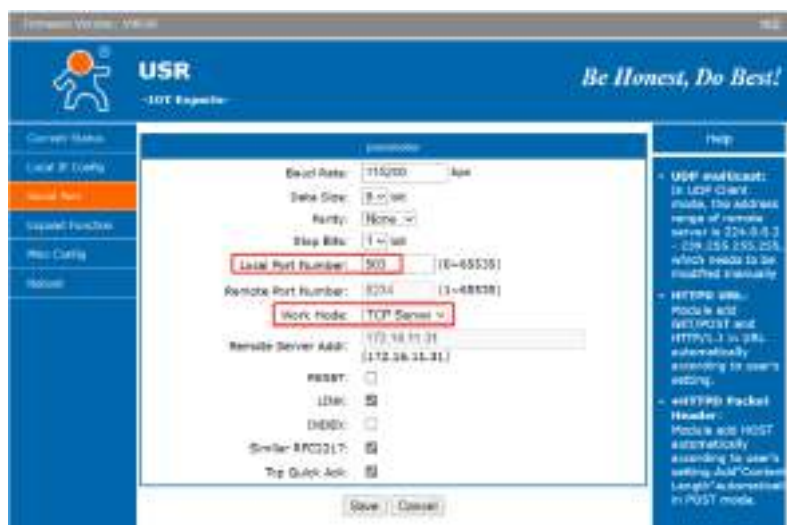

Figure 26. TCP server mode

When the device work as TCP server, it allows up to 16 clients to access. The default is 4. We can test it with test software. Setting of the software is shown in the following picture. Once the TCP connection is established, the

link indicator will turn on.

Protocol: TCP Client

Remote Host Address: 172.16.11.102 (the IP of USR-TCP232-306)

Remote Host Port: 503 (the local port of USR-TCP232-306)

The data transmission is shown in Figure 28.

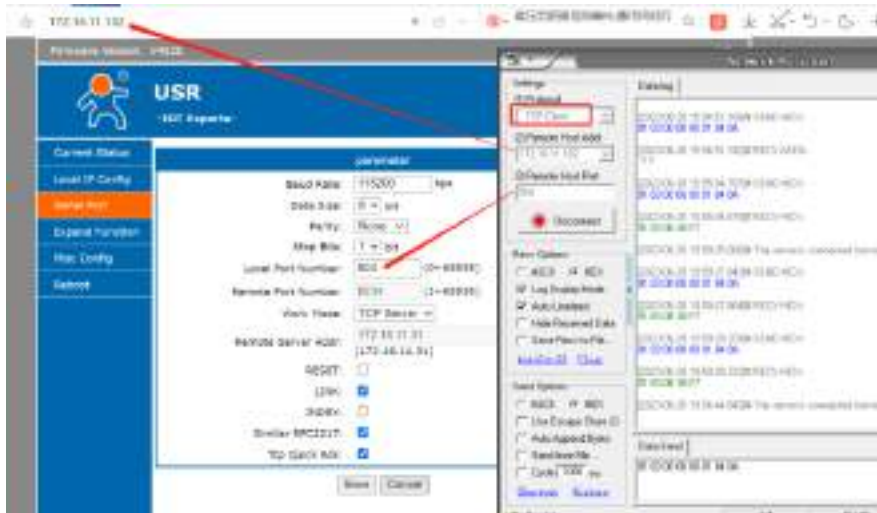

Figure 27. Setting of USR device and test software

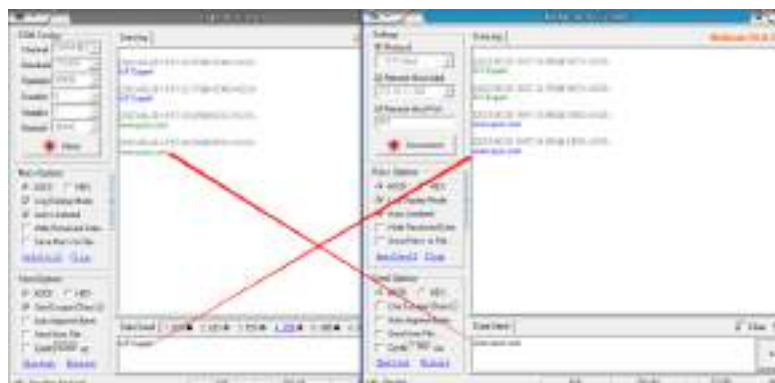

Figure 28. Test of TCP server

4.2. TCP client

When the work mode is TCP client, the remote device must work in TCP server mode. The USR-TCP232-30x will initiate the TCP connection and the remote server IP and port should be configured.



Figure 29. TCP client mode

To test this mode, the test software needs to be TCP server, and the local port should be the same with the remote port of USR-TCP232-306. After the connection is established, we can see the IP and port of USR-TCP232-306, as shown in the red box of the following picture.

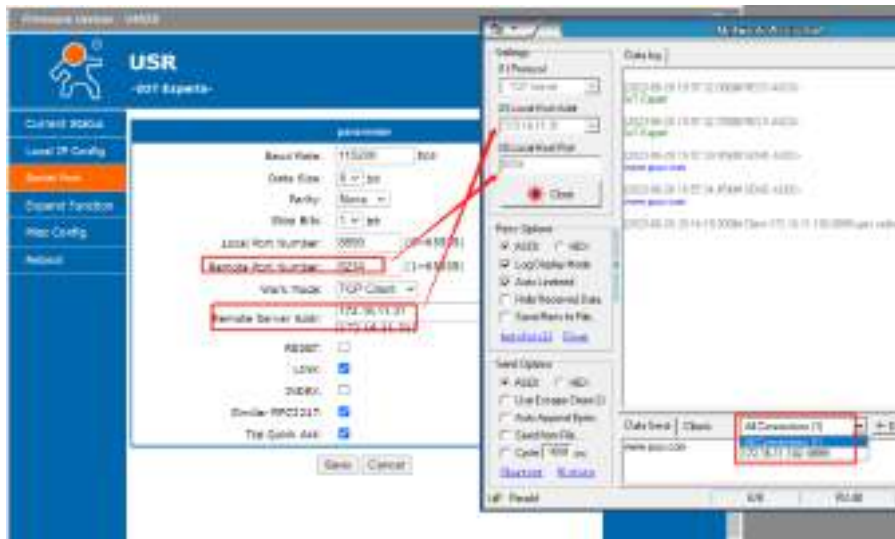

Figure 30. Setting of USR device and test software

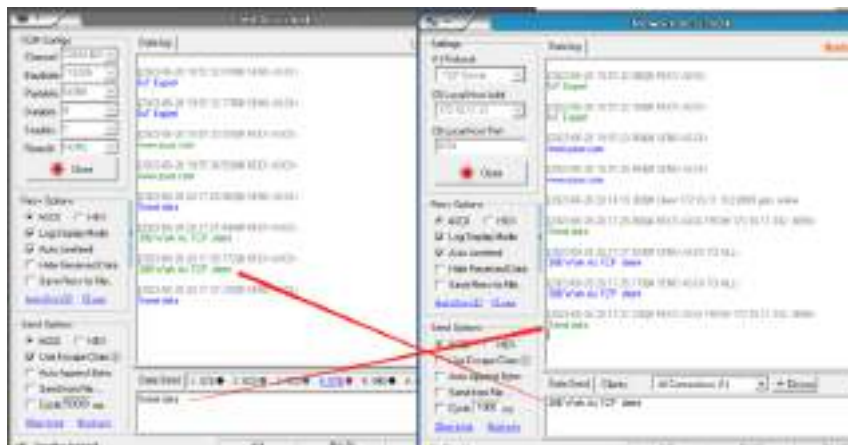

Figure 31. Test result of TCP client

4.3. UDP server

UDP is a faster and more efficient transport protocol than TCP, but it is a connectionless transport protocol. When the USR-TCP232-306 works as UDP server, it doesn't verify the source address. After receiving a UDP data packet, the destination IP and port are changed to the one which send the UDP data to USR-TCP232-306.



Figure 32. UDP server mode

For test software,

1. The local host port is the same with the remote port of the USR-TCP232-306,
2. The remote host IP is IP address of USR-TCP232-306, and the remote port is local port of USR-TCP232-306,
3. Then serial device and network device can transmit data bidirectionally.

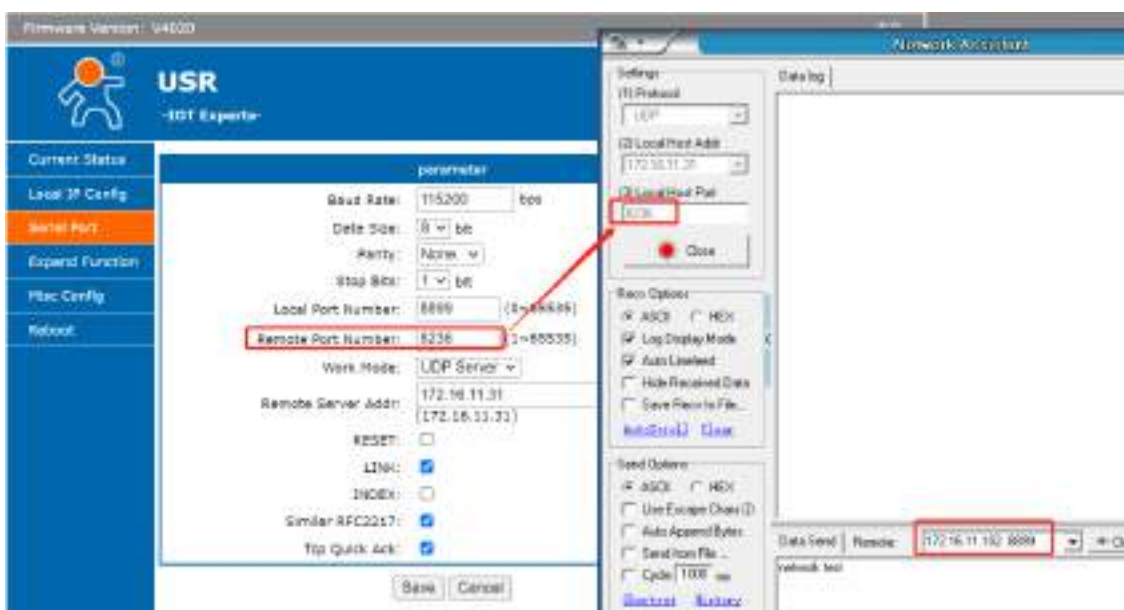

Figure 33. Settings of device and test software

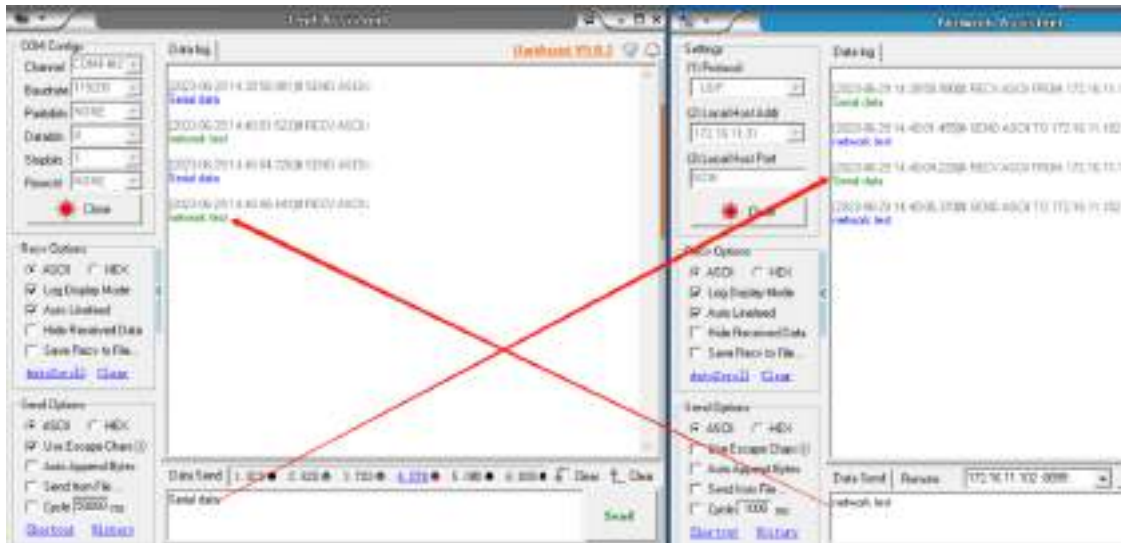

Figure 34. Test result

There is another condition, the local host port is not the same with the remote port of the USR-TCP232-306. If so, the network test software must send the first data packet to USR-TCP232-306(work as UDP server).

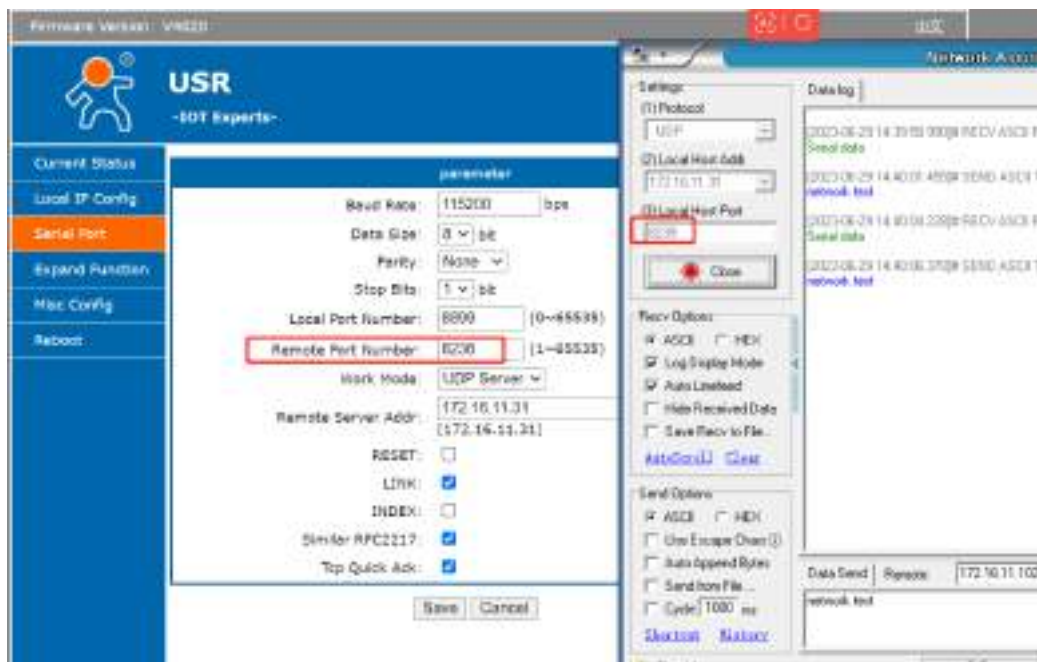

Figure 35. Different UDP port

If we send the first data packet from serial to network, the data isn't transmitted successfully, the test result can be seen in the following picture.

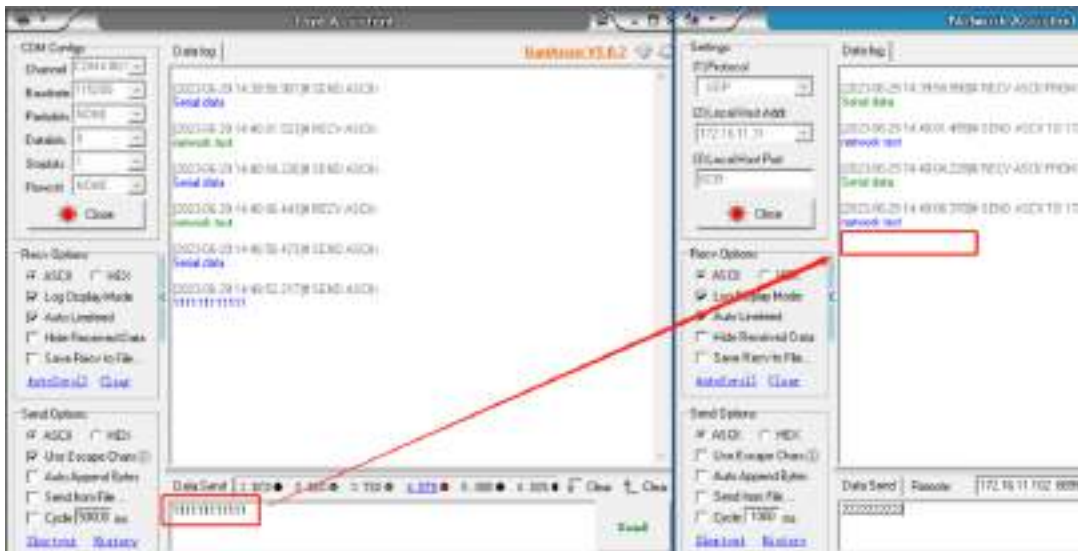

Figure 36. Test result with no data

If we send the first data packet from network to serial successfully, then we can also send the data from serial to network successfully.

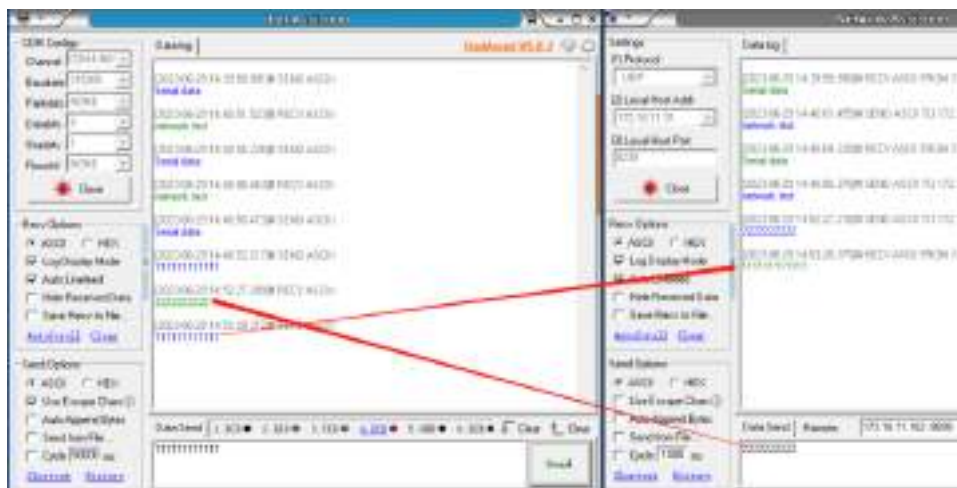

Figure 37. Test result with data transmission

4.4. UDP client

4.4.1. Transparent data transmission

In UDP client mode, TCP232-306 will only communicate with target IP/Port. If data is not from target IP/Port, it won't be received by TCP232-306.

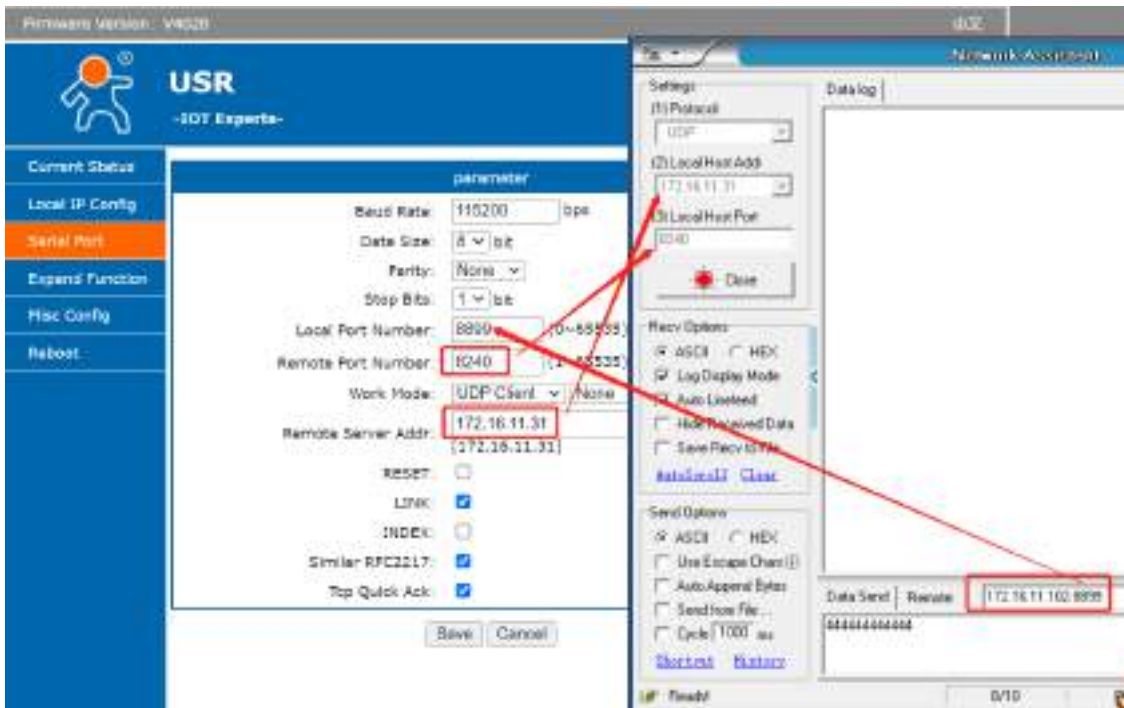

Figure 38. UDP client

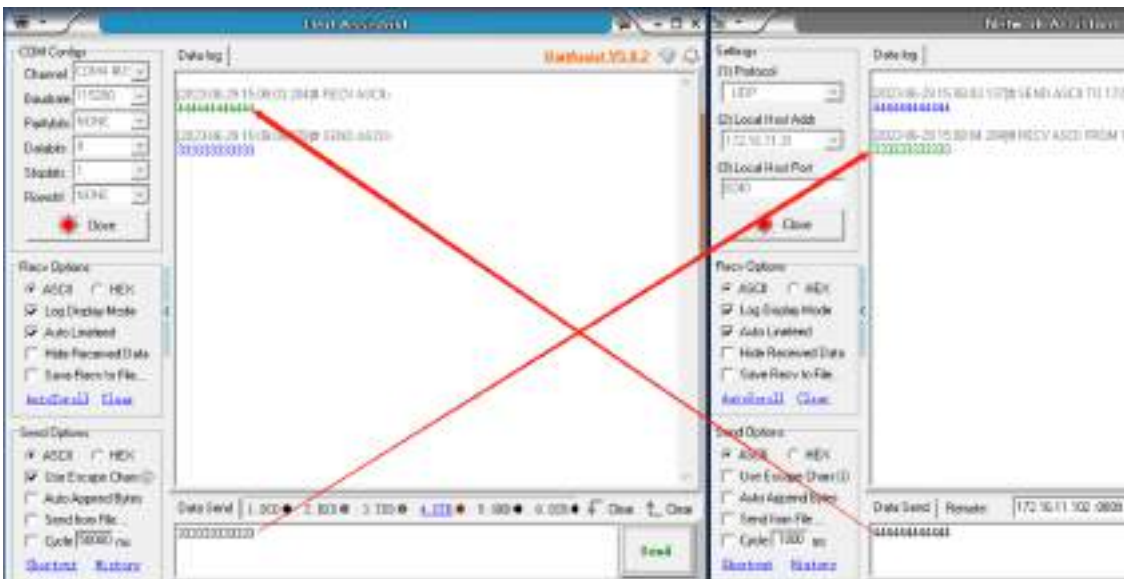

Figure 39. Test result of UDP client

4.4.2. Broadcast

If the remote IP of TCP232-306 is set to 255.255.255.255, TCP232-306 can broadcast to entire network segment and receive broadcast data.

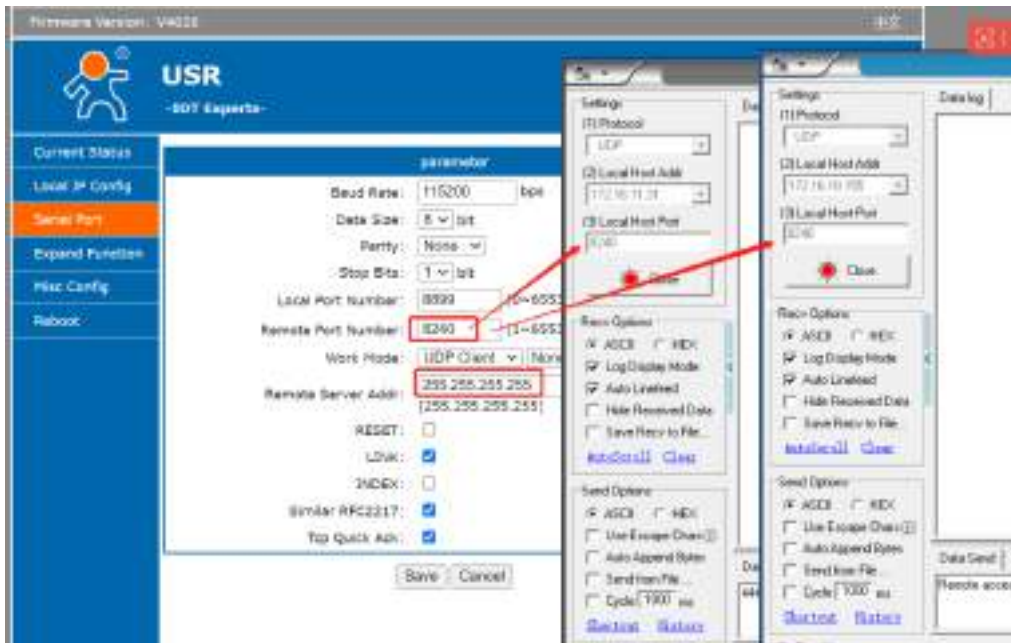

Figure 40. Settings of UDP broadcast

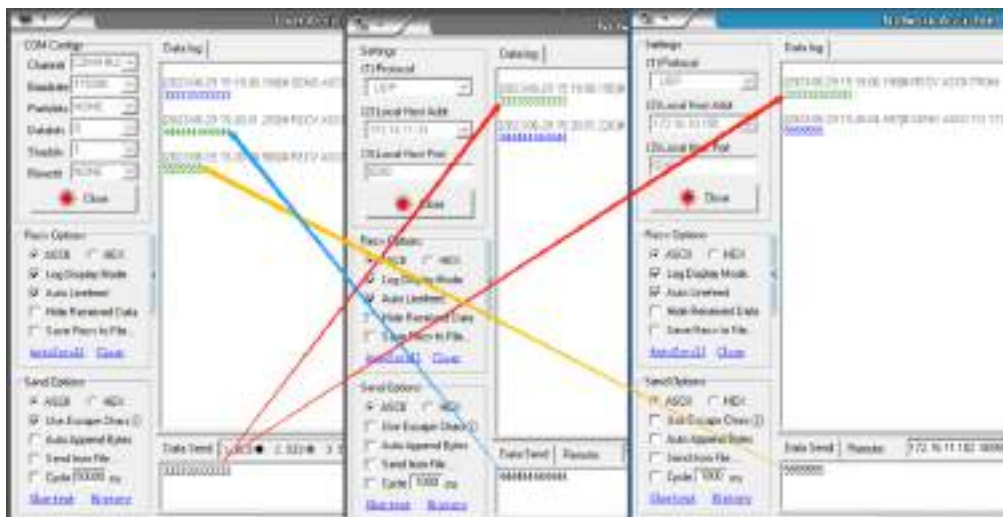

Figure 41. Result of UDP broadcast

4.4.3. Multicast

In UDP client mode, it also supports multicast. Multicast can be used to realize the one-to-multipoint connection between the data sender and receiver. Multiple receivers join the same multicast group, share the same IP address, and join the multicast group at the same time.

Members of the multicast group are dynamic, and the entry and exit of a member does not affect the original multicast group. The valid address range of a multicast group is 224.0.0.2 to 239.255.255.255.



Figure 42. Multicast settings

4.5. HTTP client

In HTTPD Client mode, TCP232-304 can achieve data transmission between serial port device and HTTP server. User just need set TCP232-306 in HTTP client and set the HTTPD header and HTTP URL and some other related parameters, then the data can be transmitted between serial device and http server.

The http connection of TCP232-30X is short connection, if the device does not receive the data sent by the serial port device after waiting for the pre-set time, it will actively disconnect. The default pre-set time is 3 second.



Figure 43. Settings of Httpd client



Figure 44. Test result of httpd client

5. Modbus Gateway

5.1. Modbus RTU to Modbus TCP

The USR-TCP232-30x series support Modbus protocol conversion. Users can enable this function in “Expand Function” tab.

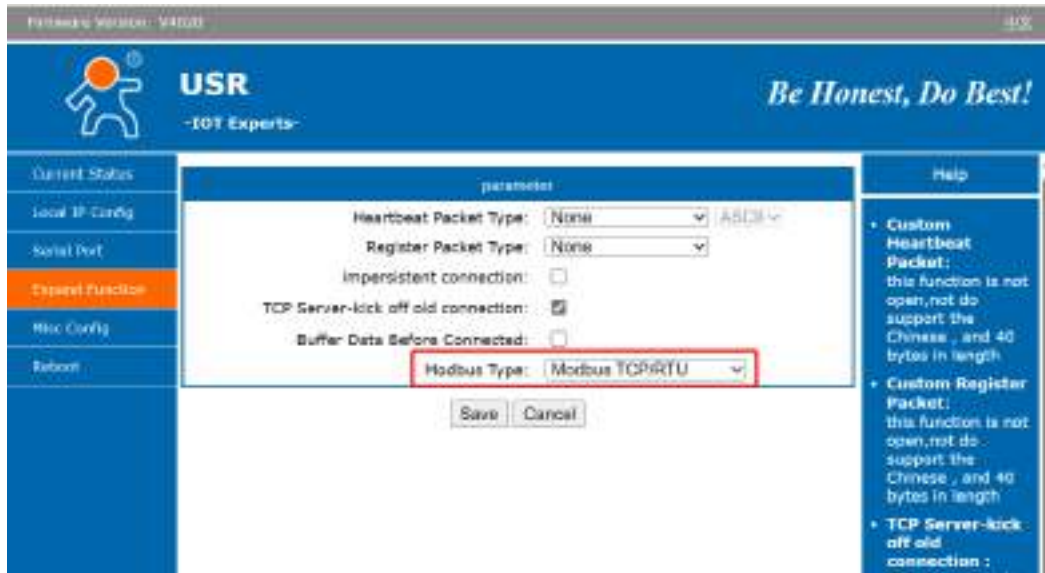

Figure 45. Modbus RTU to Modbus TCP

When users use the Modbus protocol conversion, there are two different conditions: Ethernet device works as Modbus master or serial device works as Modbus master, we will introduce the setting of these two conditions in the following chapter.

We will test this feature with Modbus Poll and Modbus slave tool which can be downloaded by Google or other search engines. You can download the Modbus tool by yourselves.

5.1.1. Ethernet master with serial slave

In this condition, USR-TCP232-30x should work as TCP server and local port can't be 0 and 80 etc. that maybe occupied by the other functions.

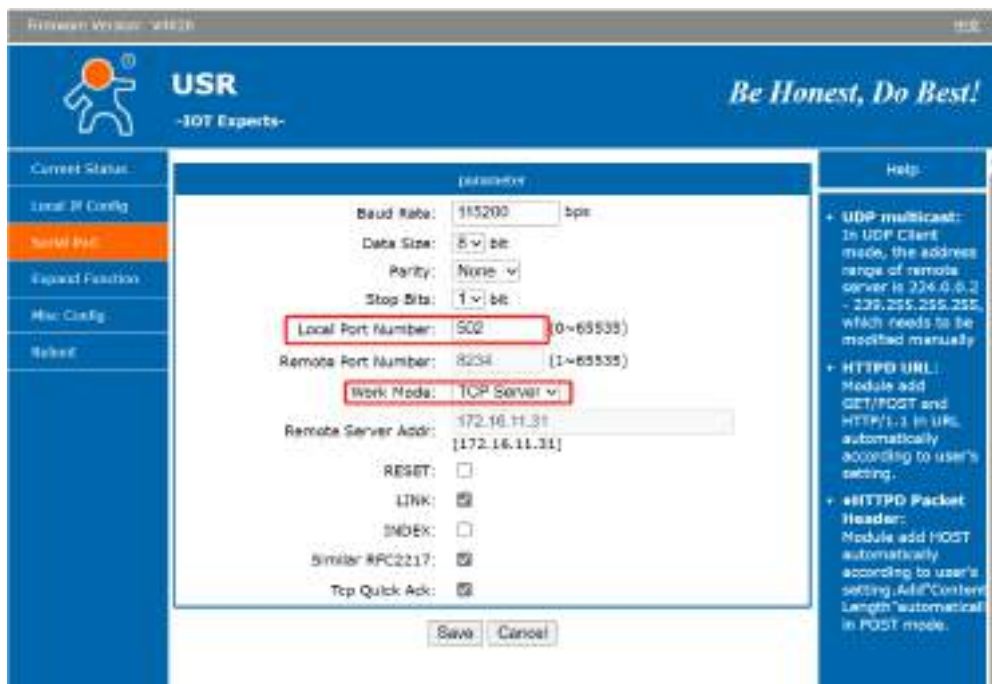

Figure 46. Ethernet master with serial slave

Settings of Modbus poll and Modbus slave and the test result. The serial parameters of the Modbus slave like baud rate, data bits and so on should keep same with the 30x'.

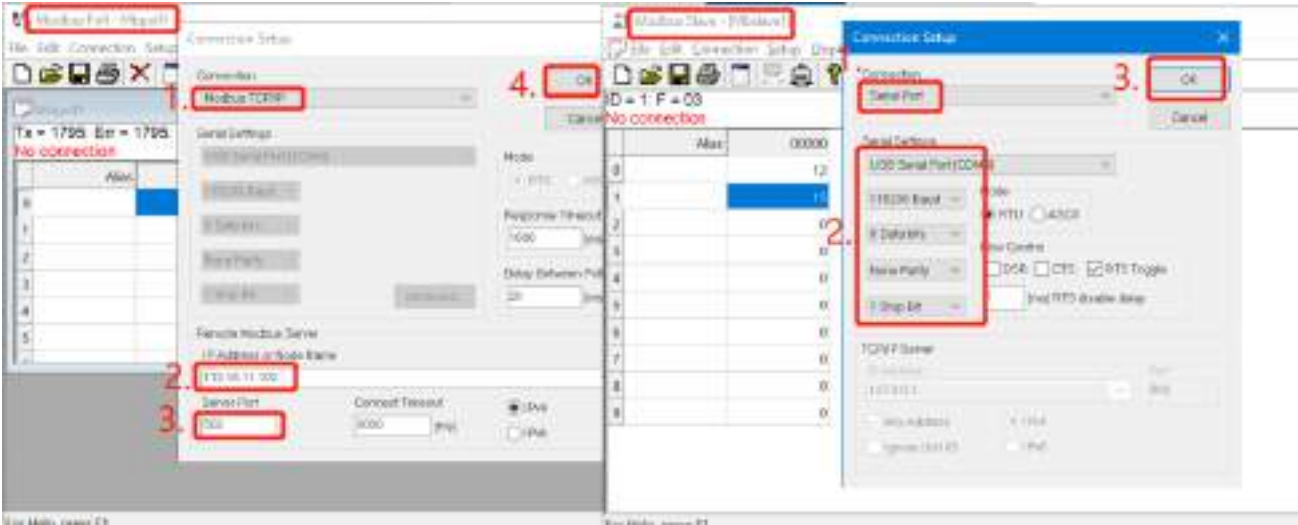

Figure 47. Settings of Modbus poll/slave

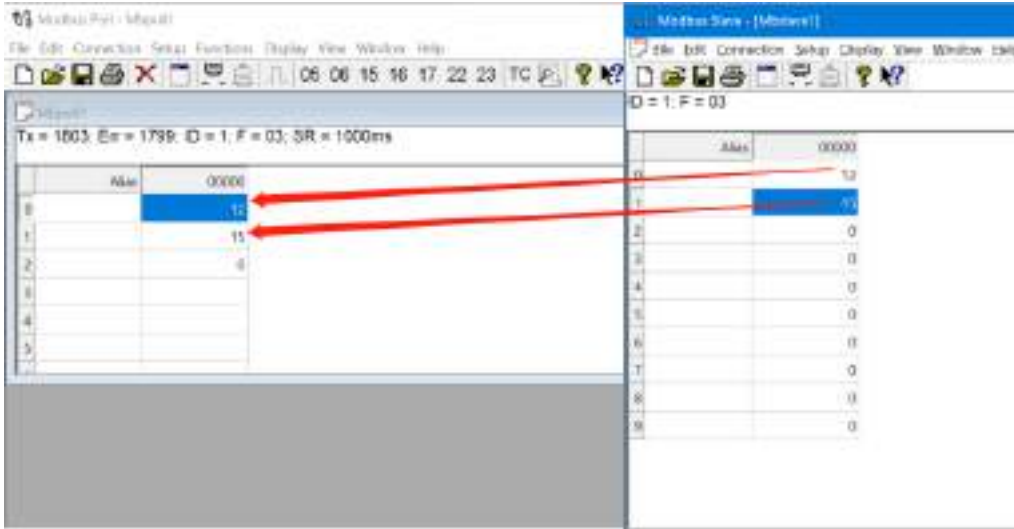

Figure 48. Test result

5.1.2. Serial master with Ethernet slave

In this condition, USR-TCP232-30x should work as TCP client and the remote port keep the same with the listening port of the Modbus slave.

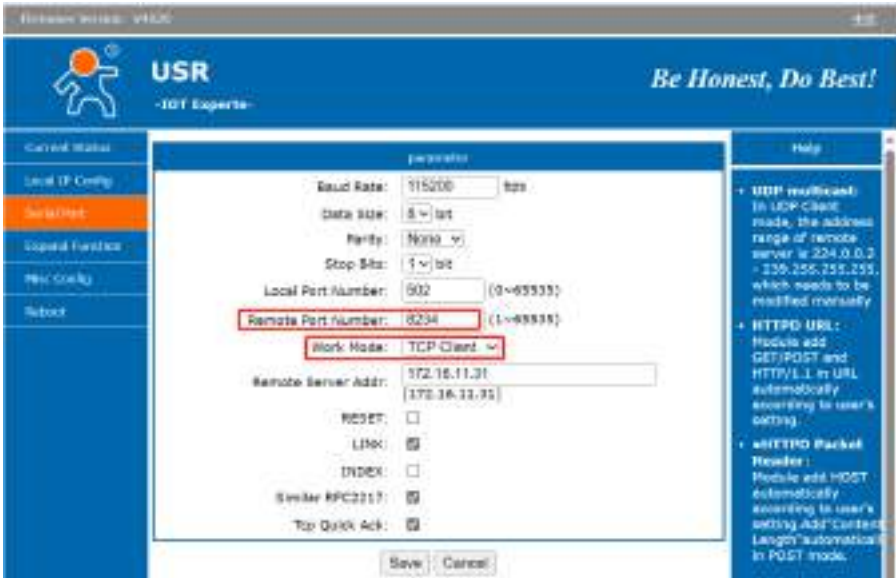

Figure 49. Serial master with Ethernet slave

Settings of Modbus poll and Modbus slave and the test result. The serial parameters of the Modbus poll like baud rate, data bits and so on should keep same with the 30x'.

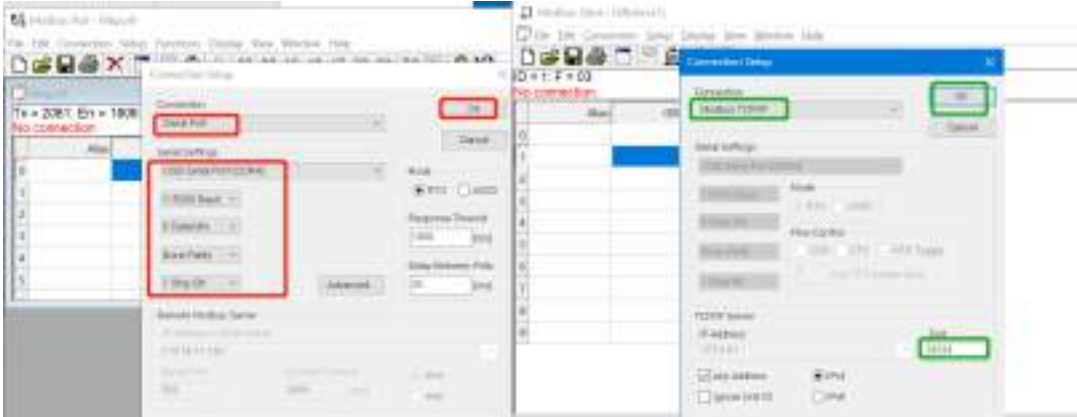

Figure 50. Settings of Modbus poll/slave

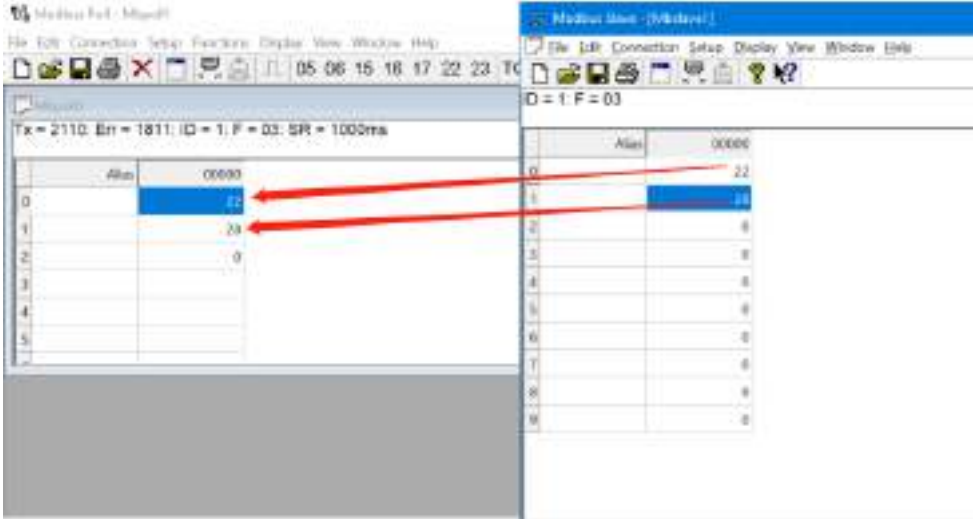

Figure 51. Test result

5.2. Multi-host Modbus polling

In practice, users need multiple hosts to monitor multiple 485 devices, such as requiring two computers to monitor the same RS485 device. The USR-TCP232-30x can solve this problem with multi-host Modbus polling. This feature can be enabled in “Expand Function” tab. In this work mode, the polling timeout is larger than polling interval.

Note: Once this feature is enabled, the Modbus master must be network device and the serial device must be Modbus slave.

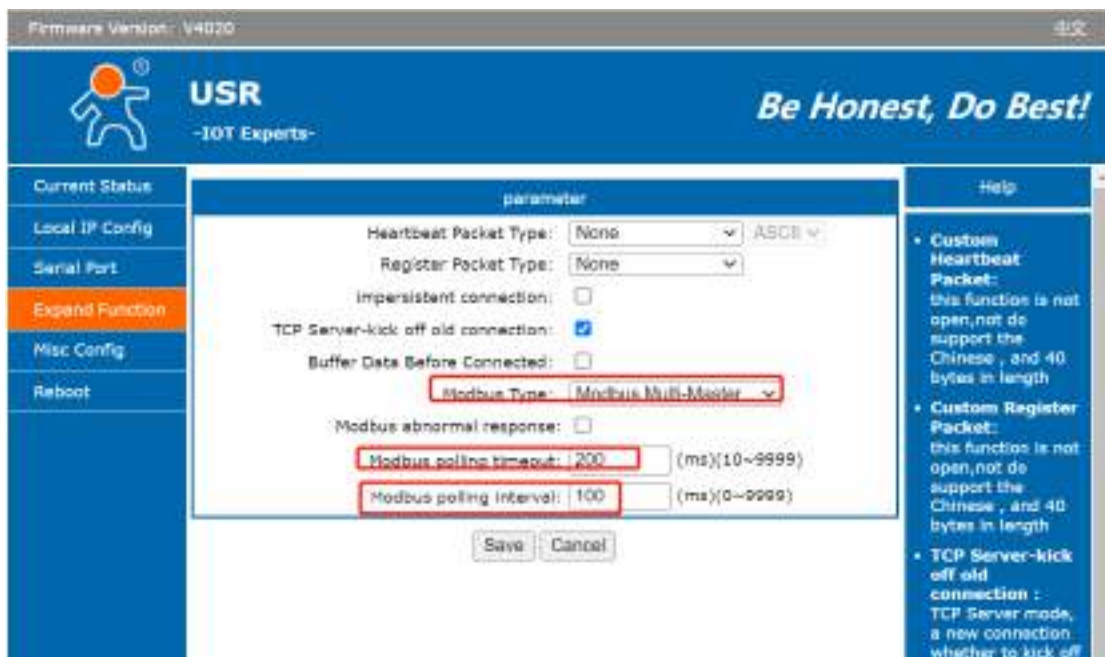

Figure 52. Settings of Modbus multi-host polling

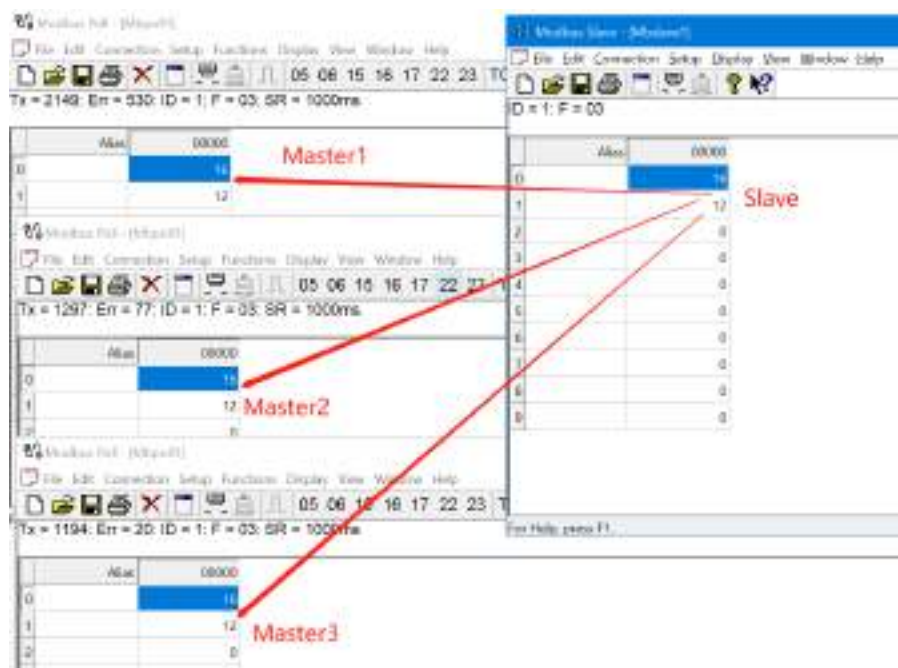

Figure 53. Test result of Modbus multi-host polling

6. Additional features

6.1. Built-in webpage

PUSR opens the source code of the built-in webpage to users. Users can modify it according to their own needs, which helps customers fully develop the products.

6.1.1. Edit webpage file

Users can download the built-in webpage package first: The file in usr_web folder can be edited as user needed.

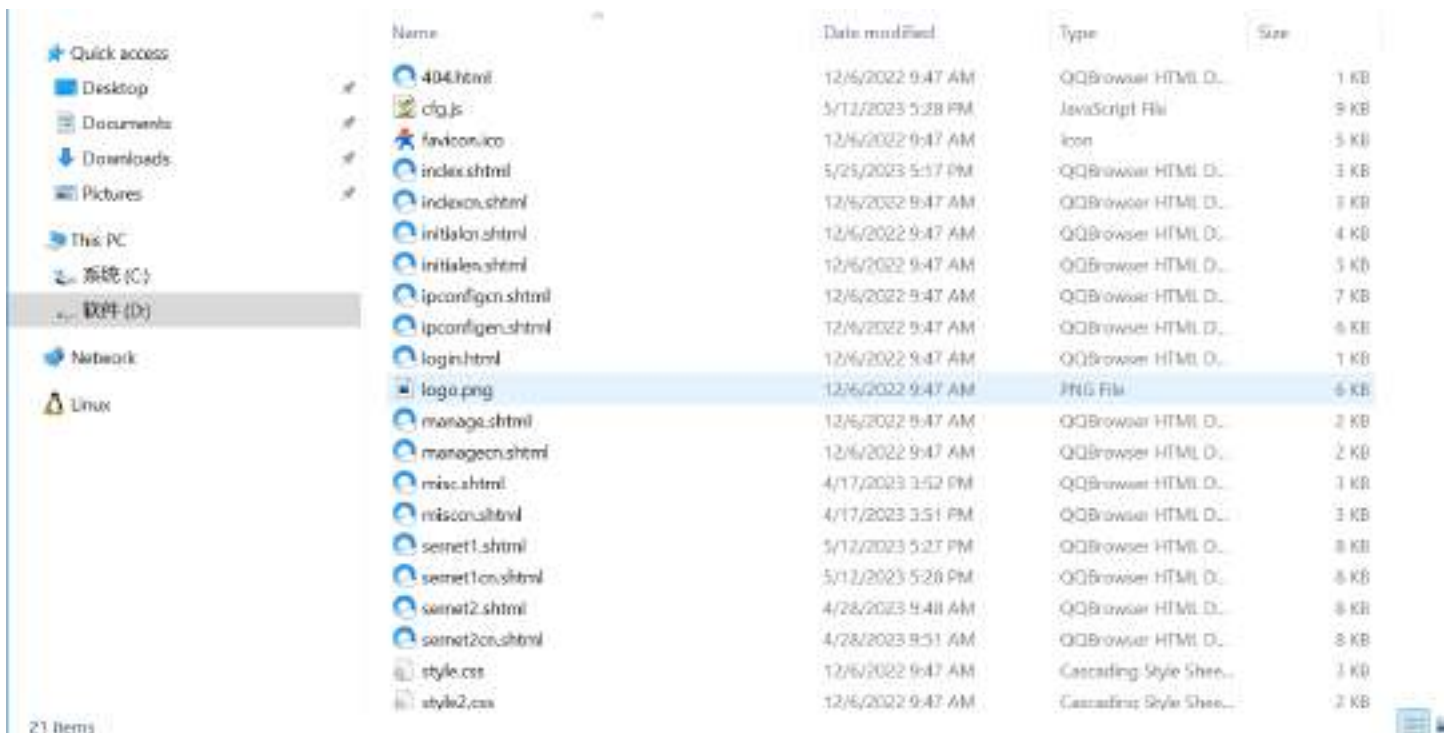

Figure 54. Built-in webpage file

6.1.2. Upgrade the webpage file

User need download the upgrade tool first,

Download address:

- Destination IP: Enter the IP address of TCP232-30X device,
- Port: Fixed 1501,
- Start Address: 08020000(Fixed),
- MaxSize: 1C000(Fixed),
- Select Path: Select the webpage file folder,
- Upgrade.

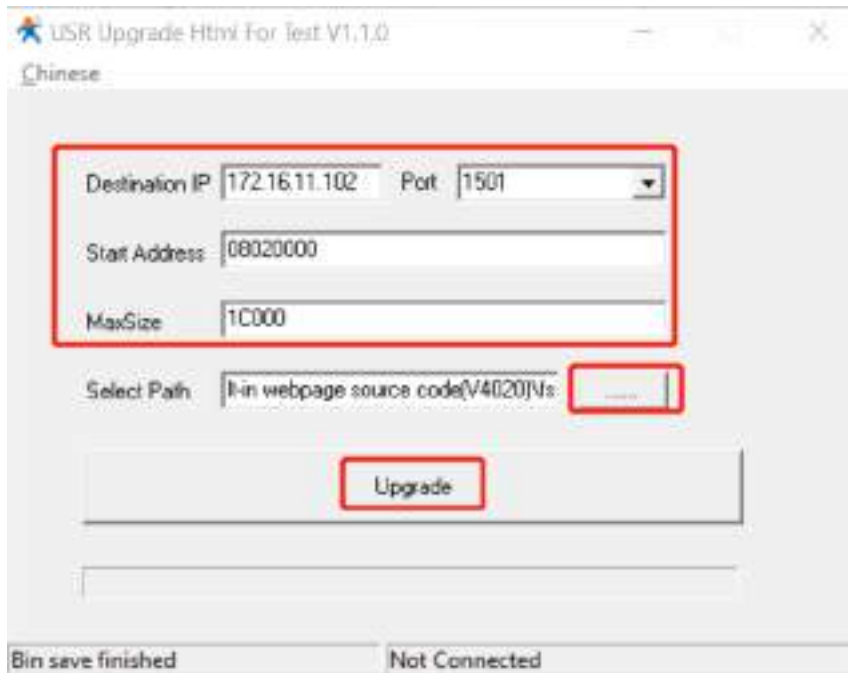

Figure 55. Upgrade webpage file

6.2. Index function

The Index function is mainly to solve the problem that in the TCP Server mode, when the user has multiple clients connected to the 30X and sends and receives data at the same time, the data source cannot be distinguished or cannot be sent to a specific client.

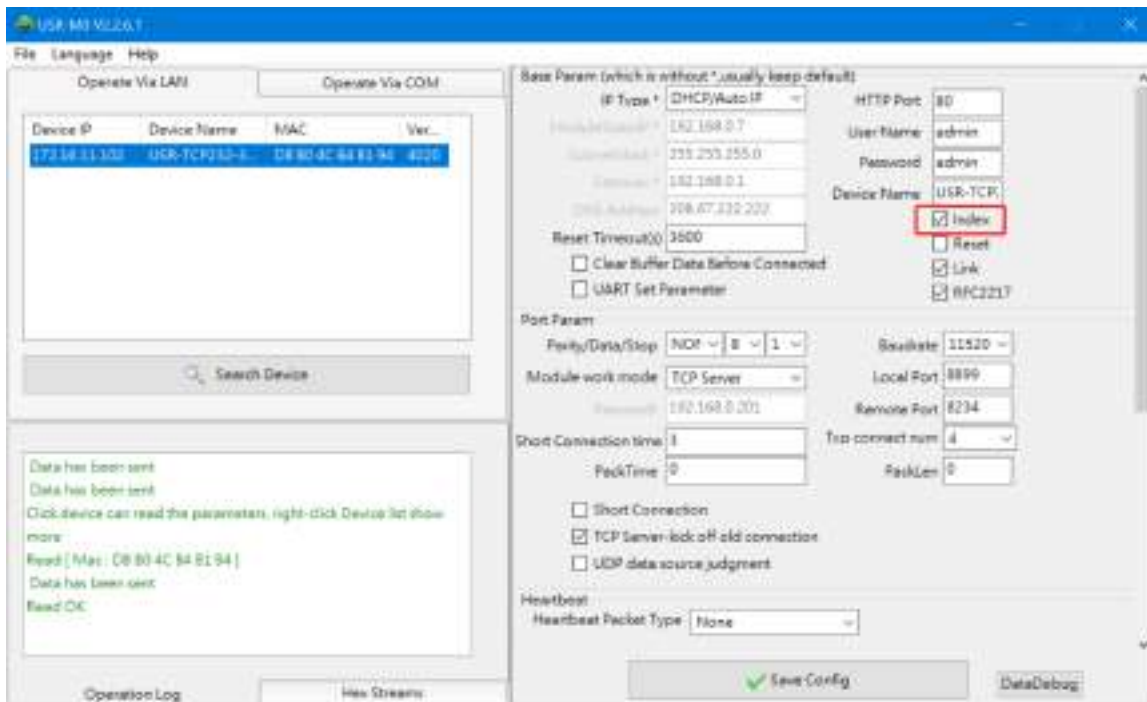

Figure 56. Settings of index function

When the TCP connection is established, the serial will out put the connection order showing in the red

rectangle. And when the clients send data to serial device, the TCP232-30X will prefix the data with a serial number like I1, I2.

When the serial device needs to send data to a specific client, such as sending data to the first client, you can add O1 in front of the data, such as we send O1www.usr.cn meaning sending **www.pusr.com** to the first clients. We can see the result in the following picture, the data is send to the first client only as indicated by the blue arrow.

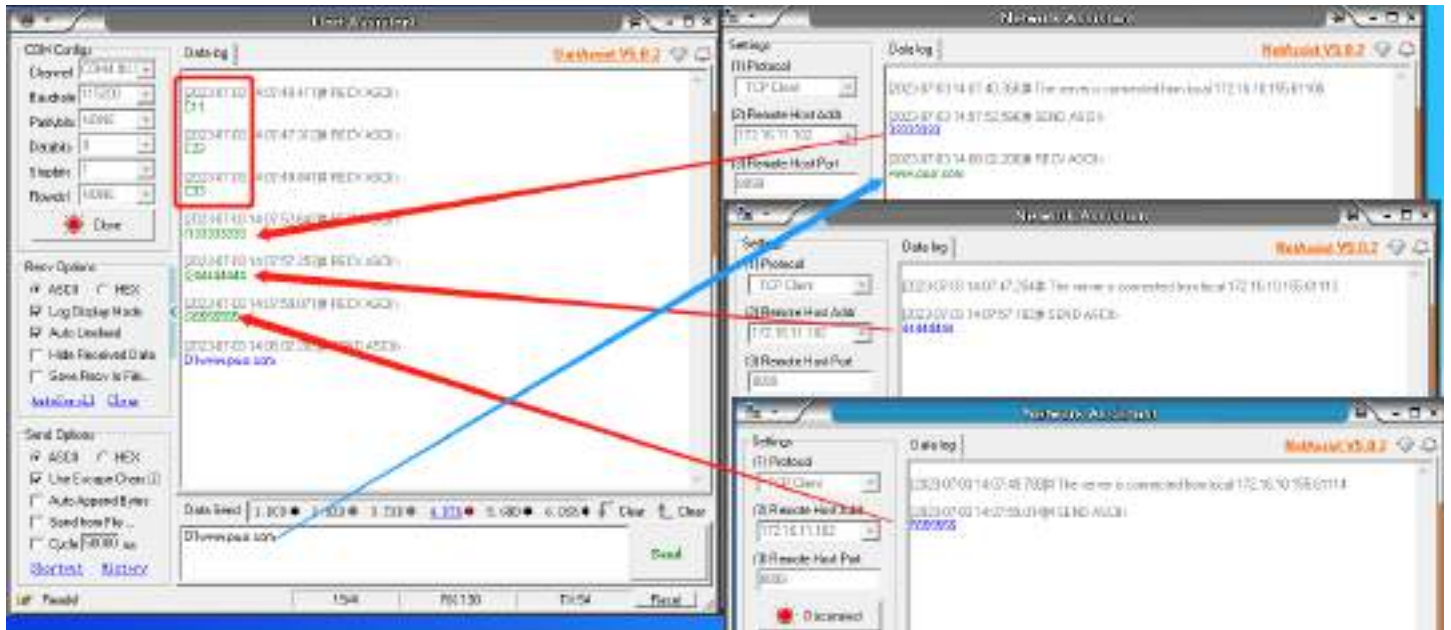

Figure 57. Test result of index function

7. Warranty

8. Contact Us

Jinan USR IOT Technology Limited

Address : Floor 12 and 13, CEIBS Alumni Industrial Building, No. 3 Road of Maolingshan, Lixia District, Jinan, Shandong, China

Official website:<https://www.pusr.com>

Official shop:<https://shop.usriot.com>

Technical support: <http://h.usriot.com/>

Email : sales@usriot.com

Tel : +86-531-88826739

Fax : +86-531-88826739-808

9. Disclaimer

The information in this document provided in connection with Jinan USR IoT technology ltd. and/or its affiliates' products. No license, express or implied, by estoppel or otherwise, to any intellectual property right is granted by this document or in connection with the sale of USR IoT products. EXCEPT AS SET FORTH IN THE TERMS AND CONDITIONS AS SPECIFIED IN THE LICENSE AGREEMENT FOR THIS PRODUCT, USR IoT AND/OR ITS AFFILIATES ASSUME NO LIABILITY WHATSOEVER AND DISCLAIMS ANY EXPRESS, IMPLIED OR STATUTORY WARRANTY RELATING TO ITS PRODUCTS INCLUDING, BUT NOT LIMITED TO, THE IMPLIED WARRANTY OF MERCHANTABILITY, FITNESS FOR A PARTICULAR PURPOSE, OR NON-INFRINGEMENT. IN NO EVENT SHALL USR IoT AND/OR ITS AFFILIATES BE LIABLE FOR ANY DIRECT, INDIRECT, CONSEQUENTIAL, PUNITIVE, SPECIAL OR INCIDENTAL DAMAGES (INCLUDING, WITHOUT LIMITATION, DAMAGES FOR LOSS OF PROFITS, BUSINESS INTERRUPTION OR LOSS OF INFORMATION) ARISING OUT OF THE USE OR INABILITY TO USE THIS DOCUMENT, EVEN IF USR IoT AND/OR ITS AFFILIATES HAVE BEEN ADVISED OF THE POSSIBILITY OF SUCH DAMAGES. USR IoT and/or its affiliates make no representations or warranties with respect to the accuracy or completeness of the contents of this document and reserves the right to make changes to specifications and product descriptions at any time without notice. USR IoT and/or its affiliates do not make any commitment to update the information contained in this document.



Your Trustworthy Smart IOT Partner



Official Website: www.pusr.com

Official Shop: shop.usriot.com

Technical Support: h.usriot.com

Inquiry Email: inquiry@usriot.com

Skype & WhatsApp: +86 13405313834

关注有人微信公众号 登录商城快速下单

Click to view more: [Product Catalog](#) & [Facebook](#) & [Youtube](#)